



Advanced Rasterizer for SD-4K SDI, HDR/WCG, SD-HD IP Generation, Analysis and Monitoring



Leader



Qx Series - Technology to power change

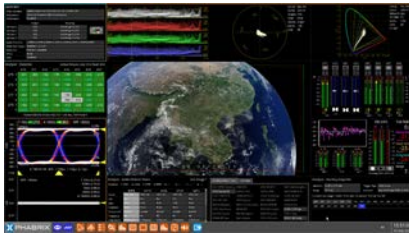

From the moment you first power up a Qx, you'll appreciate the attention to detail in a platform designed to meet the increasing demands of monitoring and testing in SD/IP hybrid environments. The Qx is equally at home in master control rooms, OB and link trucks, production studios, technical QC, product development, engineering compliance testing and operational system monitoring. Whether you are working in SD, HD or UHD, SDR or HDR, SDI or IP, conventional or remote production, Qx brings together all the user-configurability and advanced tools required for full operational flexibility when transitioning to your next generation workflows.



The Qx provides an accessible user interface and intuitive toolsets that help with rapid fault diagnosis and reduce the need for staff training. The comprehensive feature set supports SD/HD/3G/6G/12G-SDI, 10G IP interfaces, and SD/HD/UHD, IP SMPTE 2022-6, SMPTE 2110-10/20/30/31/40 with ST 2022-7, PCAP, Dolby E Decode and AMWA NMOS, easing system design and future-proofing your investment.

Analyzer/Generator - Simultaneous Operation



The Qx provides Generation and Analysis toolsets that can be used simultaneously either manually or under REST API control, enabling automated closed-loop testing of a wide range of standards and SD*/HD/3G/6G/12G-SDI formats for engineering regression testing and manufacturing. With a full suite of SDR Rec. BT 709/2020, plus native and mapped Wide Colour Gamut (WCG) HDR patterns in HLG, PQ, S-Log3 and SR-Live formats, you are equipped for flexible broadcast SDR and HDR operation.

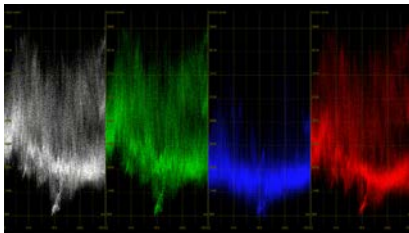

Generator and Analyzer video format, colorimetry and transfer function can all be configured independently. You have the full flexibility to simultaneously send out a UHD Rec BT.2100 HDR pattern with up to 128 channels of audio, and analyze the down-converted, down-mapped HD SDR Rec 709 return at the same time.

Compliance - it's all about Test and Measurement

Developing products or commissioning the latest equipment is more than just implementation. Equipment has to be tested against the required standards for it to be considered fit for purpose.

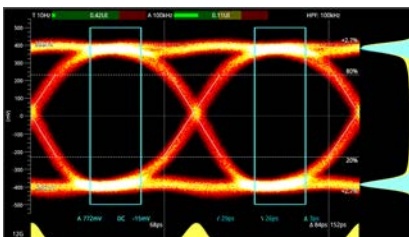

In the 12G-SDI world, noise floors are required to be much lower to ensure that accurate and meaningful measurements can be taken. Qx SDI generation and measurement technology has been specifically adapted for 12G applications. With its unique class leading SDI-STRESS toolset, sophisticated RTE™ (Real-Time Eye) multi-rate physical layer display, and automated SMPTE compliance measurements, the Qx offers a single product solution for SDI compliance verification.

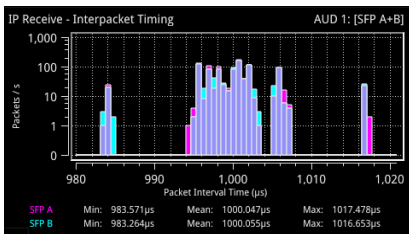

If you are working in SMPTE ST 2110, with ST 2059 Precision Time Protocol (PTP), a core IP toolset, available in the Qx offers an operator all of the IP confidence status monitoring in an intuitive and accessible manner. The optional IP-MEAS test suite provides a comprehensive set of tools for compliance verification and commissioning of your IP systems and equipment.

Hardware-based timestamping locked to PTP ensures accurate realtime deterministic timing measurements of media flows and ST 2110-21 buffer models.

Applications



Outside Broadcast

NEP UK selected Qx rasterizers for two of its new OB trucks, for use at major events and sporting fixtures. Hybrid SDI/IP capability was a key selling point for NEP enabling them to accommodate clients whether they are using conventional SDI or have made the move to IP. The ease of use of the Qx was also a major factor, making it quick and simple for both NEP engineering staff and freelancers to learn and use.

Engineering and Technical Director, NEP UK, said, "We've been very happy with the reliability of PHABRIX test and measurement equipment in the past, so it was an obvious fit to look at the Qx for these new IP-capable vehicles."



Sports and Live Events

PHABRIX recently concluded nine months of successful HDR technology trials with BT Sport in the run-up to the launch of BT Sport Ultimate. The Qx is now deployed to monitor and analyze SDR and HDR Wide Color Gamut (WCG) material on the live system. PHABRIX supported BT Sport, providing its Qx rasterizers and technical expertise, as they developed and refined their live production workflow for the launch of their new HDR, UHD and Dolby Atmos® supported proposition. On the bench PHABRIX collaborated with BT Sport to analyze and provide suggested settings for SDR to HDR converters and 'tone mappers' used in the trucks and throughout the network.



Manufacturing & Compliance Testing

Mellanox Rivermax® development and regression testing teams have been using the Qx to provide simultaneous analysis of the SMPTE ST 2110 Video, Audio and ANC DATA flows from their Rivermax® video streaming library for media and entertainment, running on Mellanox ConectX-5 and newer, Network Interface Cards," said Nir Nitzani, senior director SW development at Mellanox Technologies.

"The ability to install the Qx in the machine room and remotely access and control the realtime measurements from several sites has been an ideal fit with our engineering development workflow."

PHABRIX Qx - 10GbE / 12G-SDI Rasterizer

The flexible architecture of the Qx offers in-field license upgrades for SDI-UHD/4K, PCAP, Dolby E Decode, HDR, AV test signal generation as well as engineering grade data view and ANC packet inspection tools. A factory fitted hardware option provides RTE™ realtime SDI eye and jitter analysis with the further option of a highly advanced SDI-STRESS toolset.

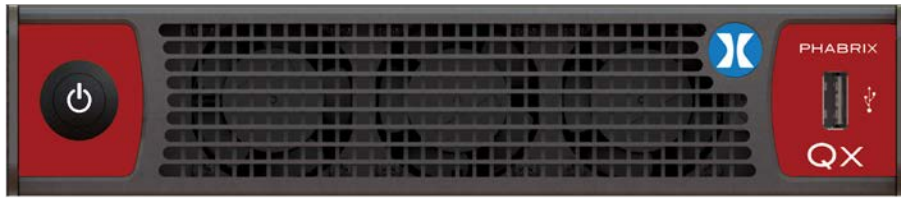

If your focus is on a classical SDI based HD facility and you would like to future-proof your operation for realtime IP, then the Qx will address your needs. The Qx features SD/HD/3G over SDI as standard, with 10G IP, UHD-SDI (6G/12G). Dolby E Decode, IP Measure, PCAP and HDR available as optional in-field license upgrades. Support for UHD/4K formats in SDI, including some HD/2K extended mode formats, can be added as an optional license (for the full list of UHD standards supported, please see page 24).

A factory fitted SDI Eye and Jitter hardware option and the unique SDI-STRESS toolset provide all the tools for SDI physical layer analysis and compliance testing.

The Qx's optional IP toolset supports payloads on native 10G SFP+ interfaces using generic IP SFPs, giving full access to be able to monitor and measure the IP traffic to SMPTE standards. In ST 2110 you can simultaneously analyze ST 2110-10/20/30/31/40 JT-NM tested* flows with Class C Audio (up to 80 channels at 125 μs packet time) all under ST 2022-7 Seamless IP Protection Switching (SIPS) and AMWA NMOS IS-04 discovery and IS-05 device connection management.

Optional in-field upgrades for IP-MEAS and PCAP provide a comprehensive set of tools for ST 2110 compliance verification and commissioning of your IP systems.

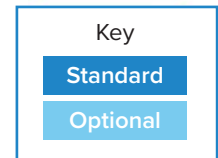
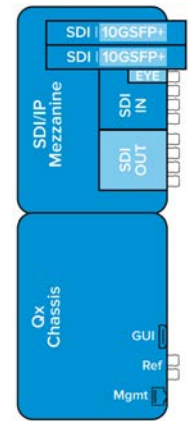

Also available in the Qx Series...

PHABRIX QxL - 25GbE/12G-SDI Rasterizer



For realtime UHD IP workflows on 25G networks with video payloads up to 21Gbps, the class leading QxL provides support for 2110 and 2022-6 on generic 10G/25G SFP28 interfaces. The QxL is 10G IP-enabled as standard, with support for simultaneous generation and analysis of a JT-NM TR 1001-1:2018, ST 2110-20 (video), up to four 2110-30 (PCM) and 2110-31 (AES transport) audio and a 2110-40

ANC media flow, all with 2022-7 Seamless IP Protection Switching (SIPS) and AMWA NMOS IS-04 discovery and IS-05 device connection management.

HDR, PCAP, Dolby E Decode and IP-MEAS are available as in-field license upgrades. Support for UHD/4K formats for both IP and SDI, including some HD/2K extended mode formats, and UHD 2110 Extended Mode formats (YCbCr/RGB 444, 8- / 10- / 12-bit; 48 to 60 Hz), can also be added as optional licenses. The SDI Eye and Jitter hardware option and the unique SDI-STRESS toolset provide all the tools for SDI physical layer analysis and compliance testing.

QxP - 25GbE/12G-SDI Portable Rasterizer



Introducing the latest member of the Qx test and measurement family - the QxP, the world's first portable, 12G-SDI, 25G-ST 2110, combined waveform monitor, generator and analyzer. This provides all of the functionality of the QxL in a handy, lightweight, portable 3RU chassis with an integral 1920 x 1200 7 inch LCD Screen with multi-touch. If you prefer buttons or mouse control then you are free to use any combinations of controls.

You can run all QxL instruments on the integral screen with minimal retraining. Plug in an external HDMI monitor and you have the same experience as if you were using the QxP as a conventional Rasterizer.

*JT-NM Tested - For more details on the JT-NM Tested Program (Spring 2020) and its test results, please see: http://jt-nm.org/jt-nm_tested/

* Upcoming Software Release

Simplicity - an interface that puts you in control

The Qx's innovative app style interface is a radical change from traditional test and measurement systems. Intuitive mouse control with context-driven dropdown menus hides the complexity of modern SDI and IP systems providing an uncluttered view of critical information. Instruments can be resized, the system auto-presenting more information as the screen area permits.

The Qx offers a fully flexible user-defined instrument layout, displaying up to 16 instruments on a single 1920 x 1080 display. Individual instruments can switch between 1/16th, 1/4 or full screen. With an output frame rate of 50, 50.94 or 60 Hz to match the video format, the GUI has adjustable brightness for controlled lighting environments.

Instrument Tabs

- Tabs along the top of a window provide quick access to different functional groups within a single instrument

Instrument Tooltips

- The UI displays context-driven tooltips providing additional information when hovering over parameters

Instrument Navigation

- Each instrument includes a pop-up submenu, giving you access to the configuration parameters of that instrument

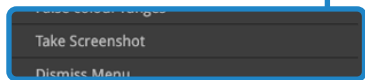
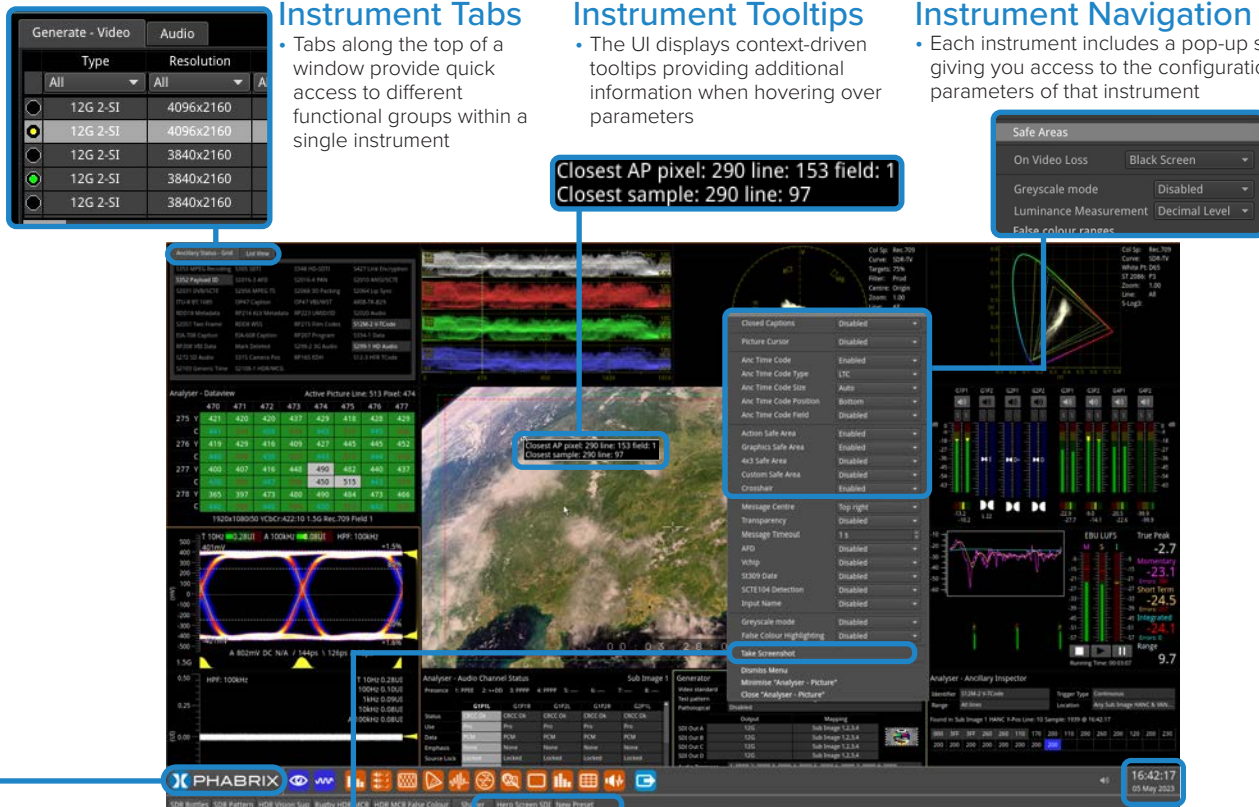

Screen Capture

- SFTP and Browser network access to event logs, screenshots, user presets

Presets

- Save multiple display layouts as presets and update as required
- Save bespoke layouts for different operational tasks
- Use to change rapidly between different screen layouts eg. Audio, HDR or IP focus

Network Time Protocol

- Configure the unit to use a date and time transmitted by a target Network Time Protocol (NTP) server or set the time and date manually in the Time and Date dialog.



Instrument Launch Menu

- Provides access to the instruments and other system menus available on the unit
- Each Instrument available in the menu is listed alongside a designated icon



Numeric Slider & Scroll Bar

- Adjust numeric values by dragging or scrolling the slider button
- Mouse over the numeric field and scroll for fine control
- Connect to USB keyboard, click and enter specific alpha numeric values

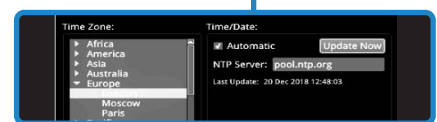

V-Err	0	0	0	0
ANC-Err	1	1	1	1
Rate (/s)	0.013	0.013	0.013	0.013

Error Highlighting

- Errors are displayed in red font

Introducing our New Waveforms

PHABRIX is pleased to announce the development of class leading Waveform Monitoring for the Qx Rasterizer. Using a technique patented by PHABRIX to efficiently deliver a high-resolution image processing pipeline with support for deep color sources up to 12-bits, this instrumentation delivers all the fine detail required fro Camera Shading, Image Grading or critical QC of both SDR and HDR content.

A choice of Overlay, Stacked and Parade display modes are provided each with the option of multi-colored, highlighted, green or monochrome traces. The flexibility to display YCbCr, RGB, YRGB, YGRB and individual components is retained along with connected instrument cursor linked to Picture and Data view, and user markers linked to Vectorscope. Single Line Mode and H and V magnification are available for detailed inspection.

Luminance Nits scales and operation user-controlled Nits markers are provided for SDR, HLG, PQ, S-Log3, SR-live HDR formats. Both SMPTE-narrow and full range operation are supported along with matrices for 709, 2020 and DCI P3 over the wide range of YCbCr:422, RGB:444, SDI, 2110, SD*/HD/2K/UHD/4K/EUHD formats for which PHABRIX is famous.

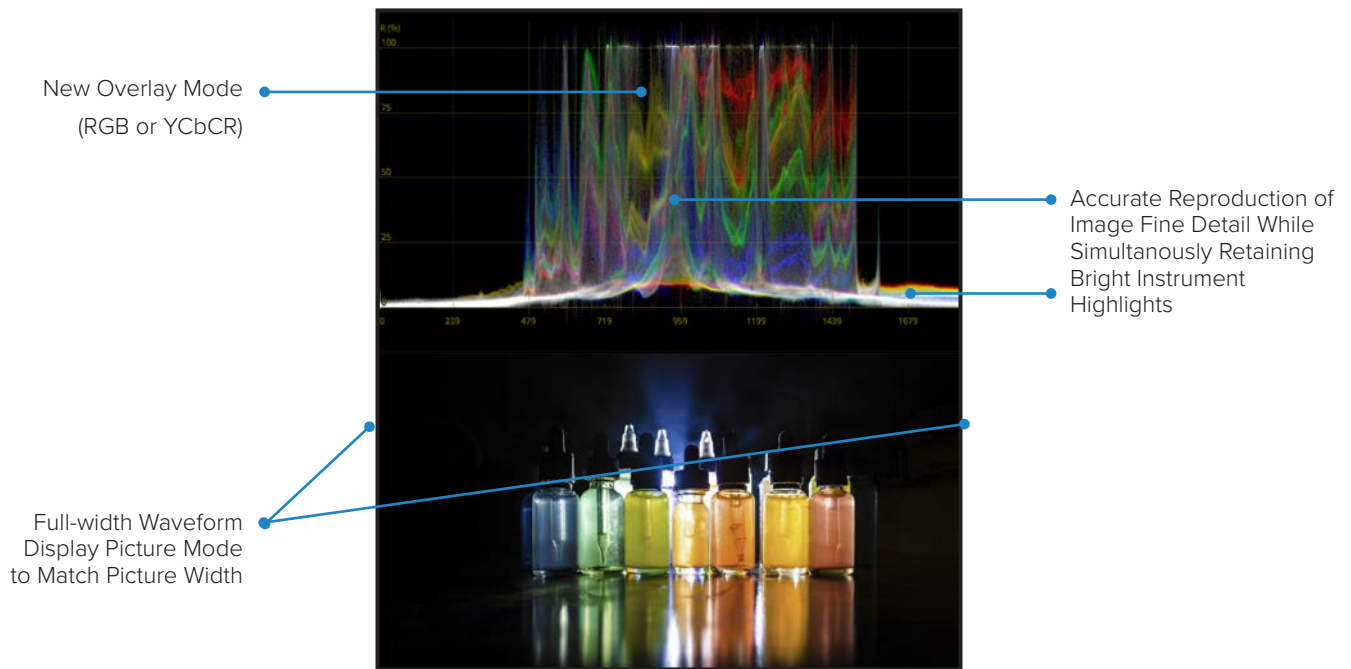

Overlay YCbCr (Color)

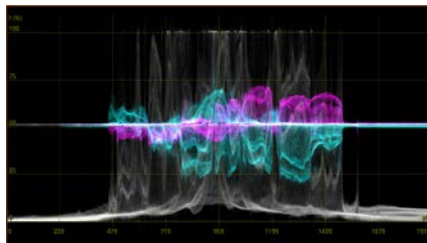

Stacked YRGB (Color)

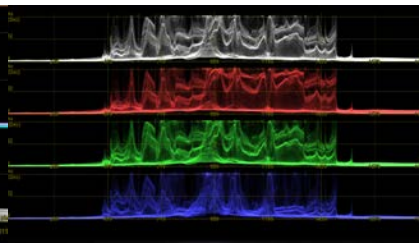

Stacked YCbCr (Color)

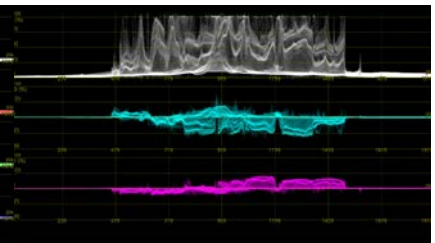

YRGB Parade (Color)

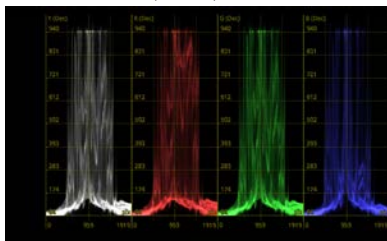

YRGB Parade (Color Highlight)

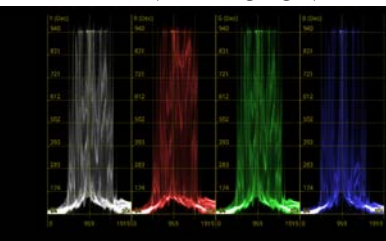

YCbCr Parade (Color)

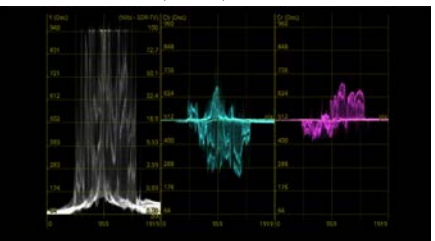

Standard Toolset



As standard, the Qx offers a flexible user-defined instrument layout displaying up to 16 simultaneous windows, and the ability to change between bespoke layouts rapidly for different operational tasks with user presets.

Picture view, waveform monitor, vectorscope, 32 channel audio metering, decoded audio channel status information, detection of common Dolby formats, ANC status and payload, on screen display of OP47 and CEA-608 in 708 closed captions and Ancillary Time Code (ATC), Loudness monitoring, and advanced control and logging with human readable event logs, remote operator GUI access over noVNC and a full REST API are all provided as standard.



Picture Display

- Cursors linked to Waveform and Data View
- Action, graphics and user-definable custom safe areas
- 1/16, 1/4 or full size display

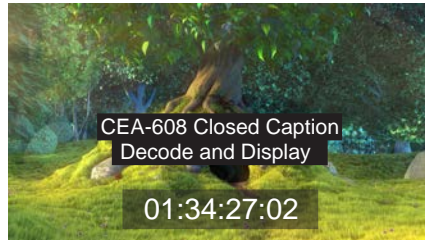

Auxiliary Data Decode

- Closed Captions OP47, CEA-608 in 708
- Primary Closed Caption decode picture window
- ANC Timecode with OSD
- Date, V-chip, AFD and Input name
- SCTE 104 indication and logging

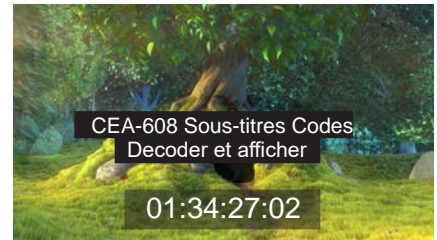

Analyzer - Picture Copy

- Secondary closed caption decode: Monitor 608/708 closed captions in a second language, or compare different screen safe areas
- Independently manage overlay elements including: Closed Captions, Picture Safe Areas, V-chip, AFD, SCTE 104, Image Center Crosshairs

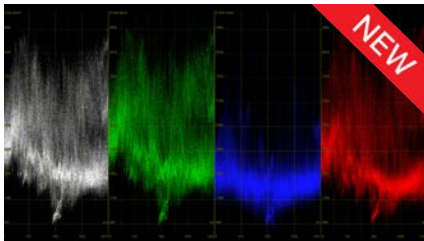

Analyzer - Waveform

- YCbCr, YGBR and GBR parade modes
- Cursor linked to Picture and Data View
- Single line mode linked to Picture Cursor
- Configurable H and V Graticules
- User markers
- Overlay, Stacked, Parade, Single line, H & V Mag, Brightness, Gamma, Persistence and Color, Highlight, Green and Monochrome controls
- 12-bit processing

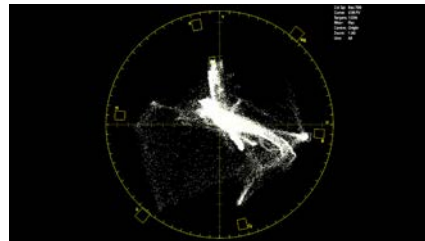

Analyzer - Vectorscope

- 75% and 100% Targets for ITU-R Rec. 709, Rec. 2020 and HDR formats
- Custom **user markers** linked to Waveform
- Center on target or custom user markers
- 0.5x to 4x Mag, center on chosen target
- Single line mode linked to Picture Cursor
- Tooltip display of Cb, Cr and Hue Angle
- IQ axis on/off
- 12-bit processing

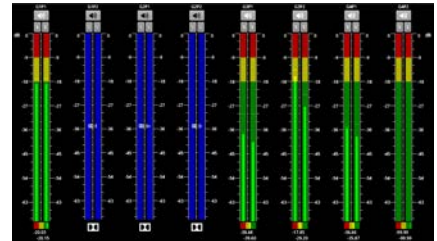

Analyzer - Audio Meters

- Open one or two audio meter windows, each monitoring a block of up to 16 channels at a time, for a total of up to 32 channels of audio metering
- 2110 audio group display across up to four flows
- Ballistics: PPM-I, PPM-II, Vu, Vu-Fr, Fast
- Scales: dBFS, dBu -18, dBu -20, BBC, DIN45406, NordiCn9
- Adjustable peak hold times: Off, 0.1 s to Inf
- Audio pair correlation meters, numerical level
- Detection of Dolby E, ED2, DD, DD+, DE line pos
- Stereo/mono audio preview bus

Analysier - Audio Channel Status						Meters 1 + 2 Flows					
Presence	Audio 2 Ch1-16: PPEE++DDPPPPPPPP					Audio 1 Ch1-16: PPPPPPPPP-----					
	Aud2Ch01	Aud2Ch02	Aud2Ch03	Aud2Ch04	Aud2Ch05						
Status	CRCC Ok	CRCC Ok	CRCC Ok	CRCC Ok	CRCC Ok						
Use	Pro	Pro	Pro	Pro	Pro						
Data	PCM	PCM	PCM	PCM	PCM						
Emphasis	None	None	None	None	None						
Source Lock	Locked	Locked	Locked	Locked	Locked						
Frequency	48	48	48	48	48						
Chan Mode	2 Channel	2 Channel	2 Channel	2 Channel	2 Channel						



Loudness Monitoring

- EBU R128 and ITU-R BS.1770
- Indicators for true peak, range, momentary, short term and integrated loudness
- User control of integrated, momentary and short term targets
- User-adjustable true peak alarm threshold
- Loudness logging stored automatically

S353 MPEG Recoding	S305 S0T1	S348 HD-S0T1	S427 Link Encryption	S382 Payload ID
S2016-1 AFD	S2016-4 PAN	S2010 AND/SCITE	S2031 DVBI/SCITE	S2036 MPEG TS
S2008 SD Packing	S2004 L19 Spk	IT08 BE/1681	OP42 Caption	OP42 WB/HST
AB08/8-820	RD018 Metadata	RP214 RLV Metadata	RP223 IAG/SD	S2020 Audio
S2051 Two Frame	RD08 WSS	RP215 Film Codes	S17M-2 VTCODE	EA-708 Caption
EA-608 Caption	RP207 Program	S334-1 Data	RP208 VBI Data	Mark Deleted
S239-2 3G Audio	S239-1 HD Audio	S272 SD Audio	S315 Camera Pos	RP165 EDH

Analyzer - Ancillary Status

- SMPTE ST 291 VANC/HANC ancillary data presence/status window
- Grid View – clear visual overview, present/absent/fault indication
- List View – ANC present list with location and status information for Checksum, Parity, DBN
- Link to ANC Inspector
- Tooltip provides ST 291 ANC type overview

Audio Status

- 32 channel indication of audio type and presence, PCM, Dolby E, DD, DD+, ED2
- Decoded channel status information for up to 128 channels
- Clear indication of useful audio parameters including CRCC, PCM/data, sample frequency, word length
- Channel Status data view (Hex)



Data View Analyzer with ANC Inspector

The engineering grade Data View Analyzer and ANC Inspector tools provide easy, accessible visualization of the data on an SDI interface and associated ANC packets. Deep SDI data inspection with full freedom to inspect Active Picture, VANC, HANC and API controls to read back Active Picture Data under automation control is included. Also featured is ANC packet decapsulation and error reporting for detailed analysis and debug of ANC payloads.

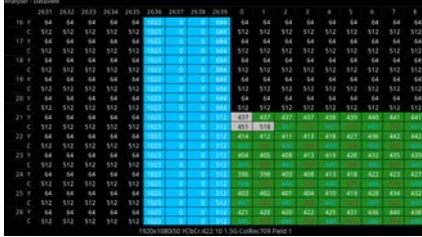

Analyser - Ancillary Inspector

Identifier: S352 Payload ID (41h 01h) | Trigger Type: Single Shot

Range: All lines | Location: Sub Image 1

Found at location: Sub Image 1 C-Pos Line 10

000 3FF 3FF 241 101 104 1CE 2C9 180 101

Data	Value
Version ID	1h 1
Payload Identifier	89h ST 2082-10 2160 Line 12Gb/s
Picture Rate	50
Progressive Picture	1h True
Progressive Transport	1h True
Sampling Structure	0h 4:2-2 (Y/Cb/Cr)
Image Aspect Ratio	0h 16:9

Analyzer - Data View

- Allows analysis of complex faults
- Detailed view of data words in the SDI stream with tooltip hint
- Navigate function for rapid access to a required line, pixel or TRS word
- Color-coding to help identification
- Cursor linked to Picture and Waveform

ANC Inspector

- Ancillary data packet analyzer
- Link from ANC Status window
- User-defined DID/SDID windowed search
- Trigger on error, single shot, continuous
- ANC packet capture with Hex view
- ANC packet decode view

I/O and Reference Configuration

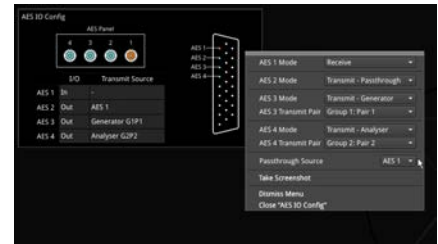
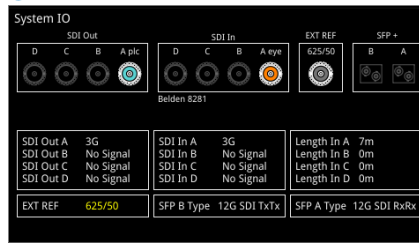
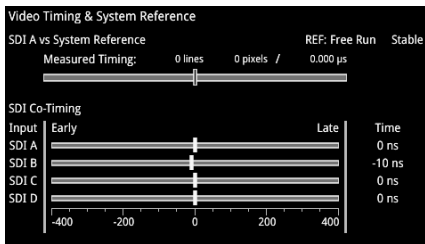

SDI Video Timing & System Reference

- Measurement of the timing of inputs against reference
- Indication of reference status and stability
- Indication of the relative co-timing of input SDI channels
- Graphical and numeric display

System IO

- Shows the status of signal inputs and outputs, external reference, cable length, and connector details
- SDI mode: Select BNC or SFP I/O, cable type, loop through and generator copy outputs
- IP mode: Active IP SFP receive inputs and transmit outputs are indicated

AES IO Config

- Four versatile bi-directional AES unbalanced interfaces
- Audio meter monitoring pair, generator audio output or AES input
- SDI Input to AES Output de-embedder for both PCM and Dolby encoded audio
- AES Input signals can be routed to other AES outputs providing up to three copy outputs

Analyser - Video Standard

Input	Payload Identifiers (SMPTE ST 352)
SDI A (1.5G)	Y-pos :2048x1080p30 RGB:444:12 DL 1.5G LinkB Rec:709 C-pos: No payload identifier
SDI B (1.5G)	Y-pos :2048x1080p30 RGB:444:12 DL 1.5G LinkB Rec:709 C-pos: No payload identifier
SDI C (No Signal)	
SDI D (No Signal)	

Standard: 2048x1080p30 RGB:444:12 DL 1.5G Rec:709

Analyser - CRC Analysis

Analysis time: 2h 58m | Last Failure Time: 11m 6s

Input Failures: 257

	Sub 1	Sub 2	Sub 3	Sub 4
C-CRC-Err	0	0	0	0
Y-CRC-Err	0	0	0	0
ANC-CS-Err	1	0	0	0
Rate (/s)	0.002	0.000	0.000	0.000
OK Time	9m 53s	11m 6s	11m 6s	11m 6s
Active Picture Changes	0	0	0	0
Active Picture CRC	EC9D CAC0	FE4F 7B21	EC9D CAC0	FE4F 7B21

Stats - SDI In A

Data Rate: 11.880000 GHz | Clock Divisor: 1.000 | Cable Length: <20m

	Sub Image 1	Sub Image 2	Sub Image 3	Sub Image 4
Counters Stable	true	true	true	true
Active Samples Per Line	1920	1920	1920	1920
Active Lines Per Line	1080	1080	1080	1080
Total Samples Per Line	2640	2640	2640	2640
Total Lines Frame/Field1	1125	1125	1125	1125
Total Lines Field2	progressive	progressive	progressive	progressive
Payload ID Y-Pos	CE C9 80 01	CE C9 80 01	CE C9 80 01	CE C9 80 01
Payload ID C-Pos	CE C9 80 01	CE C9 80 01	CE C9 80 01	CE C9 80 01

Analyzer - Video Standard

- Display of detected SMPTE S352 Payload ID for each SDI Link and Subframe
- Manual override of S352 ID
- Selection of SMPTE video format
- Indication of S352 errors

CRC Analysis (SDI)

- Check for CRC errors on Y, C and ANC
- Reporting of the number of SDI input failures, the last failure time, total analysis time and error rates
- Detect active picture changes and view the active picture CRC to observe any changes in the expected active picture CRC value
- SDI switch line CRC masking control, for SMPTE RP168 compliance checking

Stats - SDI In

- Cable length indication
- Indication of data rate and clock divisor
- Reporting of active and total pixel and line counts
- Y and C payload ID



Remote Access

Various methods are provided to enable you to establish a remote connection with your Qx system, depending on your requirements.



noVNC

- Browser remote access using noVNC technology to deliver 16 simultaneous scalable instruments over a remote network



REST API

- Control the Qx remotely over a network via a REST API
- Integrated control, monitoring and automated manufacturer testing

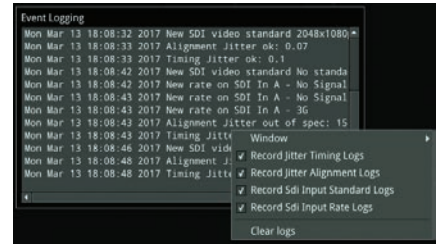

Event Logger

- SDI Input standard/status
- SDI physical layer timing and alignment jitter
- Rest API requests
- IP-Tx, IP-Rx, Flow and SFP records
- Reference Locking
- Audio input presence

LLDP Info		LLDP: Active	
	SFP A Neighbour	SFP B Neighbour	Mgmt Neighbour
Sys Name	switch-16628c	switch-16628c	phobos.phabrix.local
Sys Descr	MSN2010,Onyx,SWv3...	MSN2010,Onyx,SWv3...	Ubuntu 18.04.3 LTS Linux 4.15.0-88-generi...
Chassis ID	EC:0D:9A:FC:D0:00	EC:0D:9A:FC:D0:00	2C:4D:54:D4:07:A1
Port ID	Eth1/8	Eth1/11	00:1b:21:3a:45:d6
Port Descr			enp3s0
Mgmt IP	192.168.10.254	192.168.10.254	192.168.10.231
Primary VLAN	0	0	0

Qx Network & Automation	
Interface	Up
MAC Address	00:1F:7F:00:56:78
IP Addressing Mode	Dynamic
IP Address	192.168.0.104
Gateway	192.168.0.1
Default Gateway	192.168.0.1
DNS Server	192.168.0.10
mDNS Server	qx-022136.local
REST API	Listening on port 8080
VNC Server	No Connections

LLDP

- Identify port and device to which the Qx interfaces are connected
- Restrict information communicated over LLDP for IT security purposes
- Also available in ST 2110 and ST 2022-6 boot modes

Mgmt Interface Config

- Manual or Dynamic Addressing modes
- mDNS and DNS
- Select Default Gateway from Media or Management interfaces
- Control access to REST API and VNC



USB File Manager

- Copy presets, instrument logs, screenshots and user TIFF images to and from USB memory stick
- Delete selected files

Qx Remote Connectivity

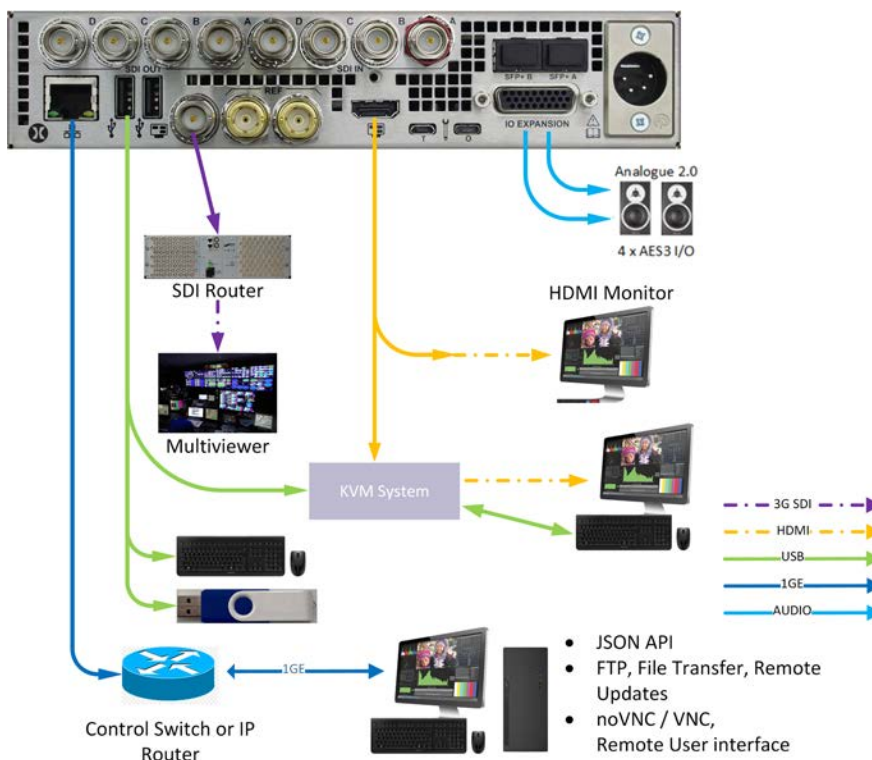

- File Transfer: FTP or Browser access to screenshots and PCAPs, User Test Patterns (TIFF), log files
- Remote Software Product Updates
- HDMI: UI video (1080p), UI audio (2-ch), local mouse
- SDI: UI video (1080p), UI audio (2-ch), local mouse
- noVNC: UI video (1080p low frame rate), remote mouse with screenshots
- KVM: HDMI or DVI (1080p compressed), remote mouse with screenshots
- ST 2110: UI (-20), Audio 2-ch (-30)
- UI audio available as analog on D26 (rear panel)
- Machine Control via JSON API
- Many KVM Options available - including Long Distance Connectivity, Cloud-based solutions, multiple access

Optional Toolsets



Fast, automated 12G-SDI physical layer analysis [PHQX01E-3G]

The Qx Physical Layer Toolset is a factory-fitted option for fast 12G/6G/3G/HD/SD*-SDI[†] physical layer commissioning, testing and development. Its RTE™ (Real-Time Eye) Technology instantly highlights any SMPTE compliance issues and its realtime SDI jitter window provides simultaneous monitoring across five specified frequency bands, jitter histogram and video trigger options. Built-in automation control allows testing to be performed faster, more reliably and at lower cost. Included in the option are a full range of SDI eye measurements including amplitude, DC offset, transition times, overshoot and health indication with both amplitude and time histograms, as well as choice of color, heat-map overlays and infinite persistence display.

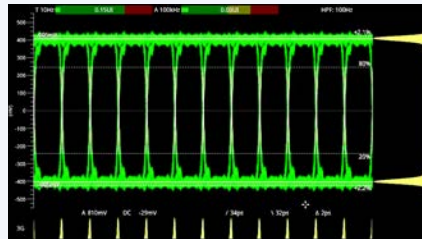
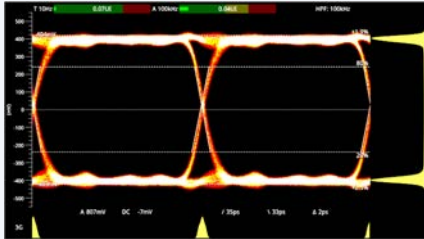

SDI EYE Analysis

- RTE™ (Real-Time Eye) for testing SMPTE compliance with indication of DC offset
- Automatic measurements of: DC level, amplitude, rise and fall time, rise/fall overshoot, visual rise time indication
- Amplitude and time histograms
- Single or multiple eyes with choice of color, heat-map overlay and infinite persistence
- Timing and Alignment jitter thermometers
- User-definable time measurement cursors

SDI Jitter Analysis

- Realtime SMPTE jitter measurements down to 10 Hz
- 10 Hz, 100 Hz, 1 kHz, 10 kHz, 100 kHz filters
- H, 2H, F, V Trigger
- Persistence control none to infinite
- +/- 0.25 to +/- 64 UI vertical scale adjustment
- Jitter amplitude histogram

Standard Eye Analysis

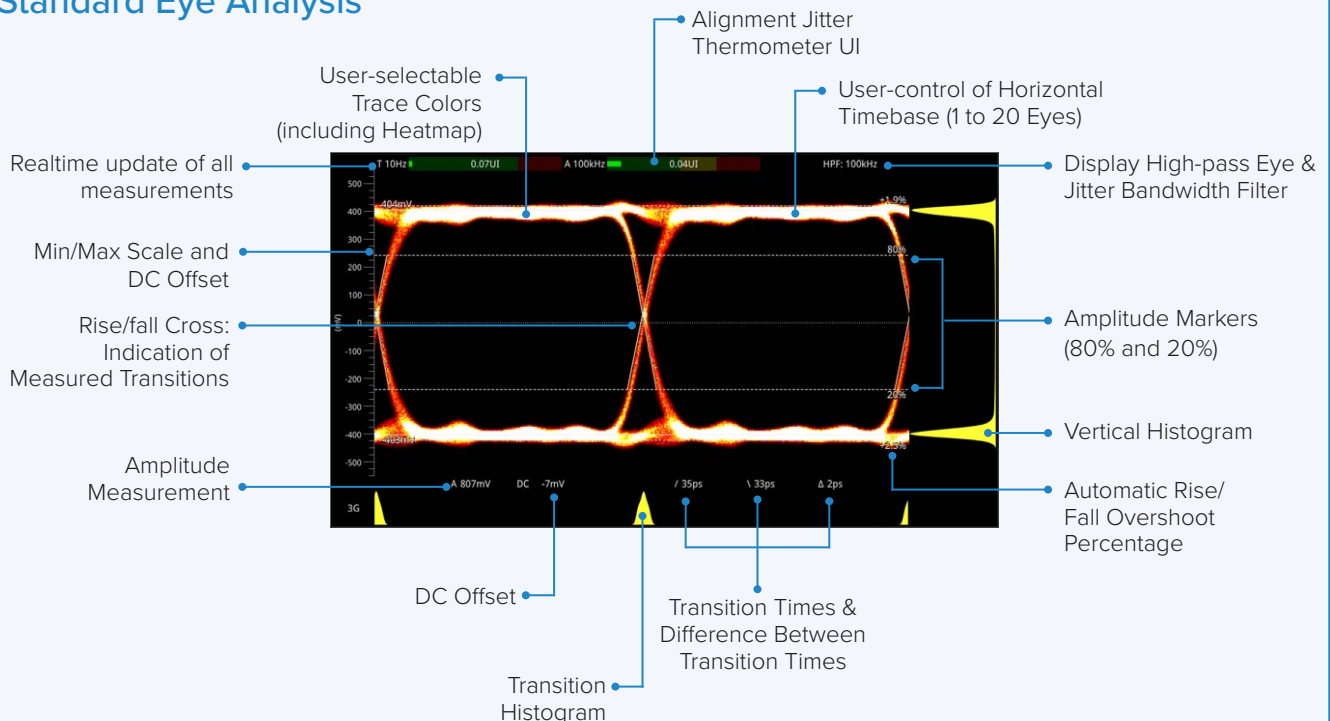

[†] Note: Optional UHD SDI formats require PHQXO-UHD

SDI-STRESS Testing [PHQXO-SDI-STRESS]

The advanced SDI-STRESS option is available for stress testing and R&D evaluations of SDI interfaces up to 12G. A comprehensive API is included for rapid automation testing. The option includes the ability, under automation control, to insert SDI clock jitter from 10 Hz to 10 MHz (128 UI max) peak-to-peak, mute any of the SDI outputs, and control the SDI scrambler, sync-bit insertion, pre-emphasis, rise time and driver amplitude. The SDI-STRESS Eye amplitude measurement provides both Shorth Mean or Mode, with a histogram overlay and a user-defined window for the exploration of eye amplitude. Pseudo-Random Binary Sequence (PRBS) generation and analysis of PRBS-7, -9, -15, -23, -31 allows for deterministic measurement of link Bit Error Rates (BER).



PRBS - Analysis

	Clock Rate	Total Rx (Gb)	Total Errors	BER
SDI A	385	3	1.9315e-10	
SDI B	385	3	1.9315e-10	
SDI C	385	3	1.9315e-10	
SDI D	385	3	1.9315e-10	

PRBS-31



Adv. Generator Tools

- Control of jitter insertion frequency and amplitude
- SDI scrambler and sync bit Insertion on/off
- SDI Bit Error (BER) insertion tool
- Control of SDI driver amplitude +/- 15%
- Control of pre-emphasis, rise/fall time

PRBS Analyzer

- Indication of PRBS cumulative received data and PRBS type
- Generation of PRBS-7, -9, -15, -23, -31
- Reported cumulative errors
- Calculated Bit Error Rate (BER)

Pathological Detector

- Generator status indication of rate at which the video pattern generator is creating SDI pathological conditions
- Indication of PLL and EQ pathological rates per second
- Detection on each active SDI link
- Realtime GPI outputs of pathological detect for external equipment triggering

Advanced Eye Analysis

(Additional features with SDI-STRESS option)

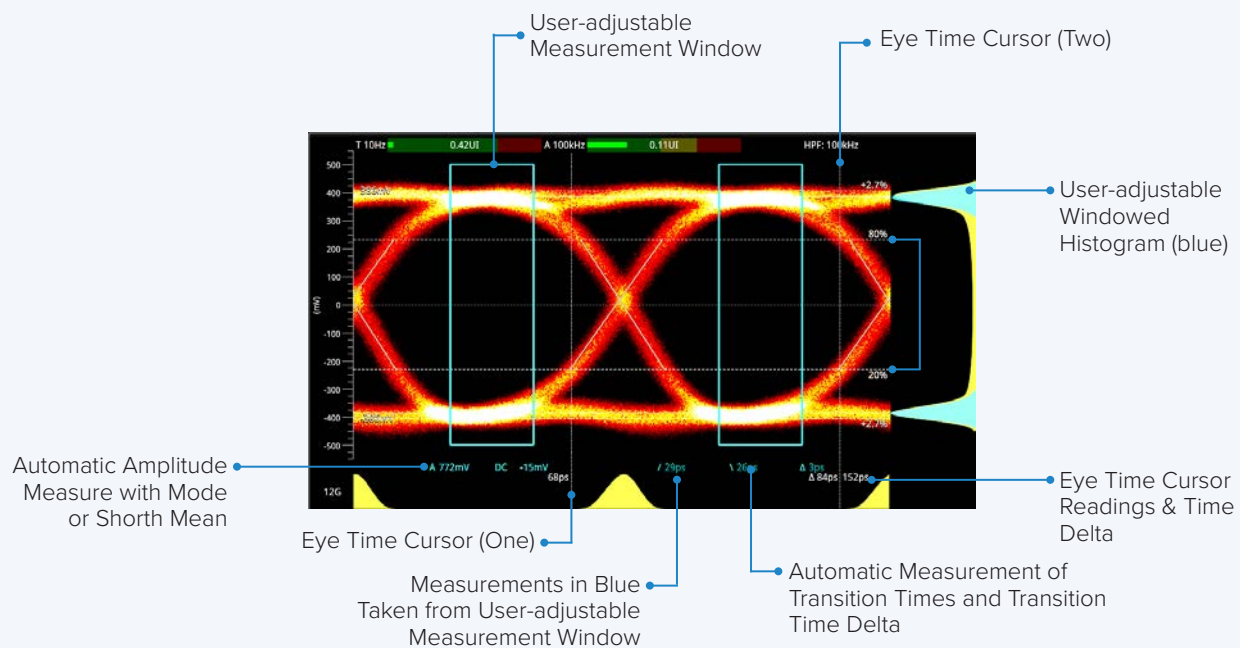

Optional Toolsets



Audio and Video Generation [PHQXO-GEN]

Simultaneously generate and analyze a comprehensive set of SDI formats with the audio and video generation option. Moving test patterns with up to 32 channels of embedded audio per link or sub-field (up to 128 channels on 12G interfaces) is included. The Generator toolset option provides not only the core full screen SDI Pathological stress patterns (Eq, PLL, Clk, CheckField), but uniquely also allows you to define a percentage combination of the SDI pathological and conventional generator patterns up to full frame. Importing TIFF files for checking of HDR/WCG graphics or display and evaluation with user-created test images is also included.

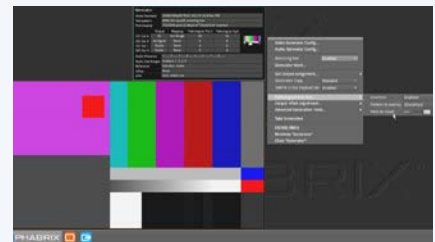
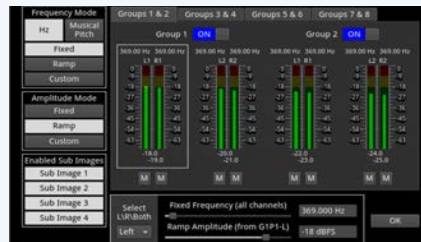
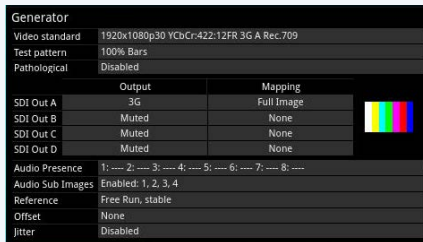

SDI Video Generation

- Confirms generated Video Standard and Test Pattern details
- BNC output, SFP output and sub-image/full image mapping information
- Video Reference, output offset adjustment and Jitter insertion (with optional SDI STRESS Toolkit) details
- Reporting of SDI-STRESS pathological insertion statistics
- Moving test patterns (bouncing box)
- Import/display TIFF images

SDI Audio Generation

- Choice of fixed tones or chromatic scale – to help with channel identification
- Choice of fixed or ramp levels – to help with channel identification
- Custom config of number of active audio groups and channels
- Master gain control
- ST 2022-6: 32 channel audio generation can be replicated in all sub frames providing a total of up to 128 channels

Pathological Generation (SDI Only)

- Conventional SDI pathological stress patterns, Eq, PLL and CheckField
- New proposed SMPTE combined pathological stress pattern: Eq + PLL + Color Bars + Clock
- Define a percentage combination of SMPTE or SDI pathological and conventional patterns up to full frame

Resolution	Frame Packing	Frame Rate	Gamut	OTF	Sampling	Bit Depth
4096x2160	Progressive	60	709	SDR	YCbCr:422	12 FR
3840x2160	Interlaced	59.94	2020	PQ	YCbCr:444	12 NR
2048x1080	Segmented	50		HLG	YCbCrA:4224	10 FR
1920x1080		48		S-Log3	YCbCrA:4444	10 NR
1280x720		47.95		S-Log3 SR Live	RGB:444	
		30			RGBA:4444	
		29.97				
		25				
		24				
		23.98				

SDI Output

Single Link Level A 2-SI

Dual Link Level B SQ

Quad Link



Select Test Pattern

Default (Luma Pixel Ramp)

OK

SDI Configuration Dialog

- 12G/6G/3G/1.5G 4K/UHD and 2K/HD SDI signal generation
- Support for Single, Dual, Quad link SDI formats. Square division, 2SI, Level A & B
- 422, 444, 4224 and 4444, YCbCr and RGB formats, 10/12 bit
- Supports the detection and analysis of SMPTE Full Range video standards

Optional Toolsets

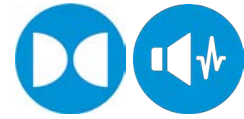

Dolby® E Decoder and Metadata Analyzer [PHOXO-DOLBY]

The Dolby E Decoder and Metadata Analyzer option provides a clear and accessible view of the Dolby E metadata present in a selected Dolby E or ED2 audio stream. It also enables you to check the correct timing of Dolby E packets in the audio signal in an SDI or ST 2022-6 broadcast chain. You can check whether the Dolby E is created correctly and transferred transparently by network equipment such as routers, switchers, satellite links, etc. You can also choose to monitor the Dolby® audio from any of the SDI/2022-6 embedded audio, 2110-30/31 or AES inputs. The decoded output and downmix can be metered, monitored, Loudness measured, and routed to AES outputs.

Dolby Metadata Analyzer

Source Pair/Channel of the Dolby Bitstream
 Dolby Begin/End Gain Values for Each Source Signal
 Program-dependant Metadata for Dolby E Program 1
 Program-dependent Metadata for Dolby E Program 2

Source	AUD2 Ch 3-4	Frame Rate	25	Original Rate	25	Bit Depth
Timecode	01:02:53.04	Config	S,1+2	Programs	2	Errors
	L	C	Ls	L1	R	Rc
Begin Gain	0.00dB	0.00dB	0.00dB	0.00dB	0.00dB	0.00dB
End Gain	0.00dB	0.00dB	0.00dB	0.00dB	0.00dB	0.00dB

- Displays the Dolby E metadata present in the selected Dolby E or ED2 audio stream
- Enables you to check the correct timing of embedded Dolby E and ED2 in SDI and 2022-6 payloads
- Check that the Dolby E metadata has been created correctly for multiple programs using the easy to read metadata display
- You can choose to monitor the Dolby audio from any of the SDI, 2022-6 or 2110 input embedded audio pairs/channels or the AES input
- Dolby stream CRC error detection and display

Dolby Detection in Audio Metering

Group Pair Labels
 Stereo Pair Selectors
 Mono Channel Solo
 Bus Selectors
 Detect any Number of Dolby E, ED2, DD and DD+ Pairs
 Numeric Values of Each Meter (dBFS)
 Correlation Indicator for Each Audio Pair
 Dolby Timing Line Number Absolute or Relative to Ideal

- Displays 16 audio meters together with peak level indicators and indication of audio pair correlation
- Dolby E, Dolby D and Dolby D+ streams are detected by the system with Dolby stream presence indicated in blue
- For an SDI or 2022-6 signal carrying embedded Dolby E audio, the Dolby E timing line number is also displayed below the detector, either as an absolute value or relative to the Ideal line number specified for that video standard

Dolby Decoder Metering and Status

8 Channels Automatically Identified from Dolby Program Metadata
 2 Channels for 2.0 Stereo Downmix of Selected Dolby Program
 8 Channel Audio Metering for DolbyE, & 2 Channels for Downmix
 Dolby Decoder Panel and Status Information

- When the Dolby E decoder is selected as the metering source (2110, SDI or 2022-6 mode), the view of the analyzer changes to display the 8 channels of decoded Dolby E audio as well as the stereo 2.0 downmix
- The meter channel identification is automatically configured from the Dolby program metadata
- Display of Dolby E source, line positioning (SDI, 2022-6), dialogue level and downmix program source

ST 2110 and ST 2022-6 Monitoring [PHQXO-IP-STND]

The optional core IP feature set provides an operator with all of the ST 2110 confidence status monitoring in an intuitive and accessible manner.

The toolset supports simultaneous decapsulation of one video, up to four audio and one ANC Data flows. Supported SMPTE protocols include ST 2059 (PTP), ST 2110-20 (Uncompressed Video), -30 (PCM Digital Audio), -31 (AES3 Transparent Transport) and -40 (ANC Data). ST 2022-7 seamless protection (SIPS) with AMWA NMOS IS-04, IS-05 and PTP system resource, is provided over two media network interfaces using industry standard optical ethernet SFPs. Audio handling conforms to ST 2110-30 Class C with support for 48 kHz streams from 1 to 10 channels at packet times of 1 ms and 1 to 80 channels at packet times of 125 μs.

Also provided is an indication of the timing relationship of each of the eight ST 2022-7 flows to PTP with status information, as well as a ST 2022-7 status tool that reports the health and relative timing skew of each ST 2022-7 pair all with hardware time stamping.

SMPTE 2110 & 2022-6

SFP IP Network		IGMP: Max V3	
		SFP E	SFP F
Carrier Signal	Present		Present
Interface	Up		Up
MAC Addr	00:1F:7F:01:56:78		00:1F:7F:02:56:78
IP Addressing Mode	Dynamic		Dynamic
IP Addr	192.168.10.147 / 24		192.168.20.15 / 24
Gateway	192.168.10.254		192.168.20.254
DNS IP Addr	192.168.10.254		192.168.20.254
Total Tx pkts	40164547451		40161328222
Total Rx pkts	322592374382		11620037
SFP E:			
SFP F:			

SFP A - Info		Temperature: 35.7 °C	Voltage: 3.22 V
		Rx Power: -4.18 dBm	Tx Power: -2.97 dBm
Status	Approved		
Vendor	Cigalight		
Part No	GPP-85192-SRC		
Vendor OUI	24-00-00		
Revision	1.0		
Serial No	M1901180211		
Identifier	SFP or SFP+		
Ext Identifier	GBIC/SFP function via two-wire only		
Connector Type	LC		
Encoding	64B/66B		

IP Receive - Flow Select		Multicast Requests: 1678 pairs seen				Analyzer Interface: SFP			
SFP	Seq	Protocol	Type	Dst IP	Src IP	SSRC	Bandwidth	Packets	Seq errors
A	2110-30	IP	239.168.20.120000	192.168.10.141-190000	0	1.888 Mbps	440103604	0	0
A	2110-30	IP	239.168.20.120000	192.168.10.141-190000	0	21.888 Mbps	440103604	0	0
A	2110-30	IP	239.168.20.120000	192.168.10.141-190000	0	2.733 Mbps	440103604	0	0
A	2110-40	IP	239.168.20.120000	192.168.10.141-190000	0	43.373 Mbps	19737628	0	0
B	2110-20	IP	239.168.20.120000	192.168.10.141-190000	0	1.001 Mbps	810722099	0	0
B	2110-30	IP	239.168.20.120000	192.168.10.141-190000	0	21.888 Mbps	440103604	0	0
B	2110-40	IP	239.168.20.120000	192.168.10.141-190000	0	43.373 Mbps	19737628	0	0
B	2110-50	IP	239.168.20.120000	192.168.10.141-190000	0	2.733 Mbps	440103604	0	0
B	2110-60	IP	239.168.20.120000	192.168.10.141-190000	0	40.433 Mbps	19737628	0	0
B	2110-40	IP	239.168.40.120000	192.168.10.141-190000	0	43.373 Mbps	19737628	0	0

SFP IP Network

- Reporting of presence of SFPs, SFP MAC and IP addresses (flow source IP address), and interface status
- Tx and Rx packet counters for indication of traffic activity
- User configuration of SFP IP Addresses, Masks, Gateway and DNS addresses

SFP Information

- SFP status information for monitoring the physical network connection
- Indication of SFP vendor and laser characteristics
- RX and TX power for debug of fiber connectivity

IP Receive

- Reporting of the IP Flows available to the receiver and user selection of the required flows
- Indication of Qx locked status, Protocol, Src and Dst IP and Port Numbers, SSRC, Packet Counts, Sequence, payload and CRC errors
- Configuration of Multicast Destination IP addresses and subsequent Multicast Join requests

SMPTE 2110

SFP A - PTP Info		Standby System Reference	
GM Info	Qx Status	Messaging	
Communication Mode	Multicast (M/M)	Appl freq adjustmnt	
Delay Req Interval	Using GM value	Appl freq adj delta	
Announce Rec't Grace Period	3	Offset from Master	
Latency Offset	0 ns	Steps removed	
Local PTP State	Listening		

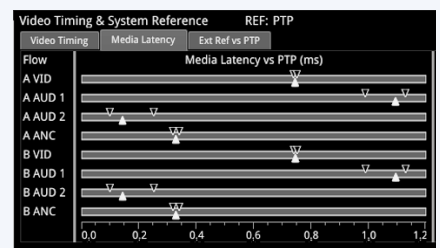

ST 2110 PTP Info - 2 port

- Control of PTP domain and communication mode (multicast, hybrid w/o negotiation)
- Indication of lock status
- Grandmaster information including leader ID and time source
- Indication of estimated frequency and phase lock offsets
- Indication of one step or two step traffic
- Two independent PTP followers

ST 2022-7 Status

- Indication of the health of ST 2022-7 seamless protection
- Warning of ST 2022-7 flow-pair mismatch
- Warnings of errors on flows and errors on reconstructed output and error rates per second
- Relative measure of Path Differential of flows on SFPB (Blue Network) relative to SFP A (Amber Network)
- Class A, B, C, D markers

IP Flow Latency

- Indication of media latency
- Indication of relative timing of audio and ANC flows with respect to video
- Indication of relationship of underlying media to PTP
- External analog reference timing with respect to PTP

AMWA NMOS

A suite of AMWA NMOS tools that provide flexibility when integrating with an NMOS controller and associated network topology. Supported protocols: IS-04 v1.0, 1.1, 1.2, 1.3 IS-05 1.02, 1.1 and IS-09 PTP domain. Provision of both in-band and out-of-band control topologies with manual, mDNS, DNS-SD and DHCP. Receivers can be independently configured as single or dual NMOS end points. NMOS troubleshooting is aided by the simultaneous views of the state of the Receiver Master and RTP Enables, SDP, and the IS-05 parameters. The receiver auto-detected video format and audio packet time and channel count are compared with the received SDP information for diagnosis of the format information supplied by the SDP record.

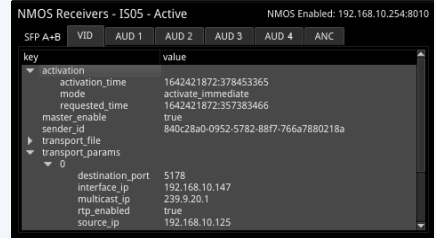
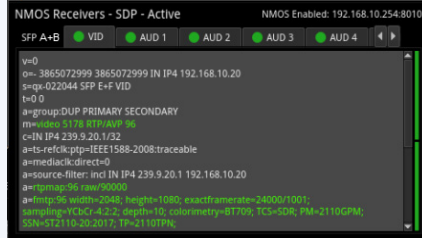
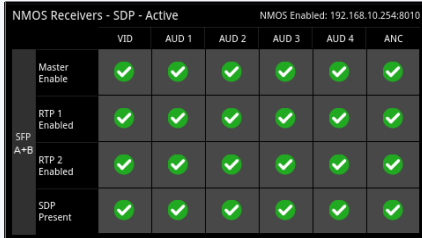

NMOS Receiver Status

- At a glance overview of the state of the receiver Master Enable, RTP Enables and SDP records for each media interface
- Available in 1/16 view - toggles with the SDP view
- Display of the Master, RTP and SDP of all Receiver flows

NMOS Receiver SDP

- Display of the active receiver SDP record
- User configurable color highlighting for improved readability
- Display adapts with NMOS Dual or Single receiver configuration (Dual shown)

NMOS Receiver IS-05

- Display of the active receiver IS-05 parameters
- Individual tabs for the display of the IS-05 parameters for each receiver flows
- Human readable tree view of the IS-05 JSON with expand/collapse for rapid navigation
- Display adapts with NMOS Dual or Single receiver configuration (Dual shown)

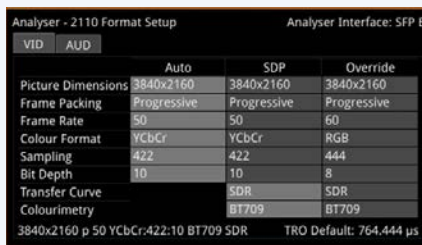
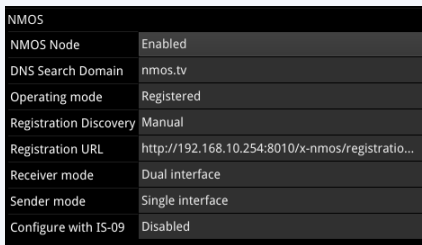

NMOS Setup

- Manual, mDNS or DNS-SD discovery of the Registry with DHCP
- Status reporting of registration and DNS domain
- Independent configuration of sender and receiver as single or dual NMOS endpoints
- NMOS node Enable/Disable
- IS-09 PTP Domain Enable/Disable

2110 Format Setup

- At a glance comparison of auto-detected, SDP and manual format settings
- User-configurable video format parameters for ST 2110-20 flows
- User-configurable audio format parameters for ST 2110-30/31 flows includes packet time and channel count
- Automatic detection of audio format, channel count and packet time

Optional Toolsets



10G PCAP Tool [PHQXO-IP-PCAP]

This Packet Capture (PCAP) tool provides a flexible range of options for your capture of the live IP traffic on either a single or both Media interfaces while in ST 2110 Mode. The PCAP data is then saved to USB memory stick for offline analysis using third-party network analysis tools. The PCAP data on the USB stick can be accessed remotely via Web Browser.

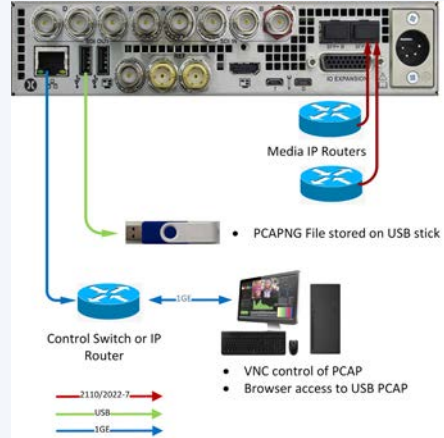
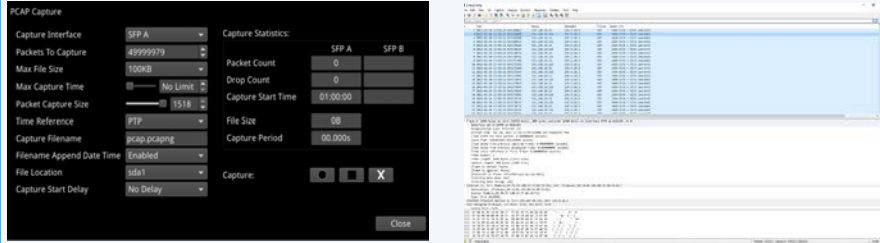

- Full line-rate capture at 10 Gbps on a single interface, back-to-back packets
- Capture data on one or both media interfaces simultaneously up to 20 Gbps
- User control of packet capture size - e.g. Full payload or headers only with user control of the Packet Capture size (12-1518 Octets)
- Manual Start-Stop, Auto Start-Stop at specified time, Capture Start Delay
- User controls for auto stop: Number of Packets, File size, Duration
- Saves to USB stick with the option of Browser File transfer off the unit
- 1 GB PCAP max. file size on Qx.

IP Network Traffic Measurement [PHQXO-IP-MEAS]

An advanced engineering suite of tools for ST 2110 analysis and debug offers the provision of up to four simultaneous dual Packet Interval Timing measurement windows per input for easy visualization of network congestion and sender packet distribution with max, mean and min inter-packet arrival times. Also included is detailed data reporting of flow packet, clock rates and PTP timing relationship, as well as the measurements of the ST 2110-21 Network Compatibility Model (C_{INST}) and Virtual Receiver Buffer Model (VRX). Advanced measurement of IP flow latency and RTP clock timing relationships for debug of Audio, Video and ANC alignment, source PTP and encapsulation are featured.

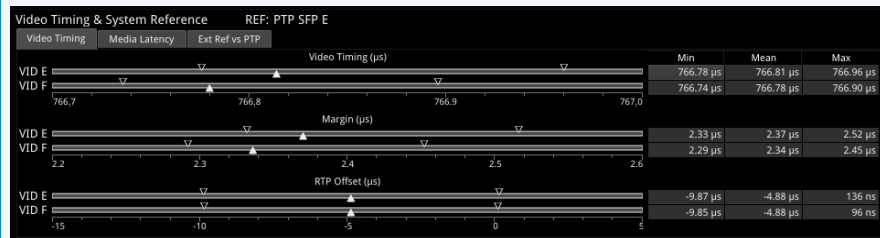
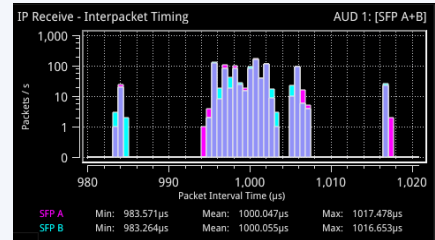

Inter-packet Timing

- Stream health reporting using histogram to show the distribution of inter-packet arrival times
- Simultaneous reporting of ST 2022-7 primary and secondary flow
- Packet counts (log or linear scales) mapped against arrival times (µs)
- Easy diagnosis of congestion with max, mean and min inter-packet arrival times

Advanced Media Timing - Video

- Time of First Received Packet of a Frame (video timing)
- Receiver Buffer Margin with respect to TR0default
- Sender RTP offset

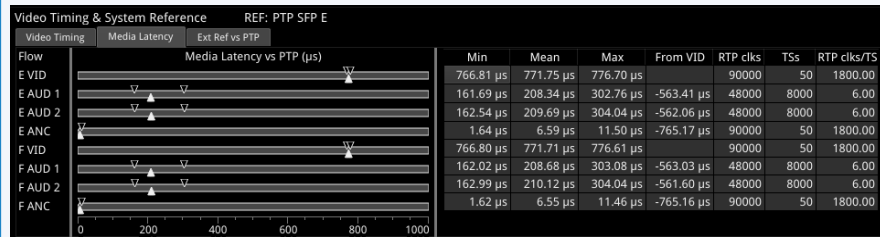
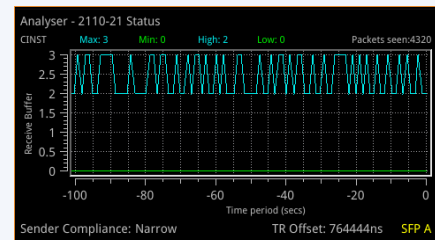

ST 2110-21

- ST 2110-21 measurement of Network Compatibility Model (C_{INST}) and Virtual Receiver Buffer Model (VRX)
- User control of VRX buffer read-schedule timing
- User control of C_{INST} buffer drain rate

Advanced Media Timing - Media Latency

- Numerical display of Mean, Min and Max latency measurements
- Measured RTP clocks/s, Timestamps/s and RTP clocks/timestamp interval
- Numerical display of Video to Audio and ANC relative latency measurement

Packet Interval Profile Generator

[PHQXO-IP-NGT] (Requires PHQXO-GEN)

A ST 2022-6 packet generation tool for evaluating the ability of a receiver to handle a ST 2022-6 flow with jitter. Simulate IP video network packet jitter under a variety of network conditions by providing the ability to adjust the transmission distribution profile. View the interval timing distribution of the packets being generated, the number of packets being generated each second, against the deviation of each packet interval from the expected interval time.

IP Transmit (ST 2022-6)

- Configuration of Transmission flow addresses, port numbers and SSRC
- Inter-packet jitter onto outgoing flow
- Gaussian or uniform distribution
- Flow control on/off

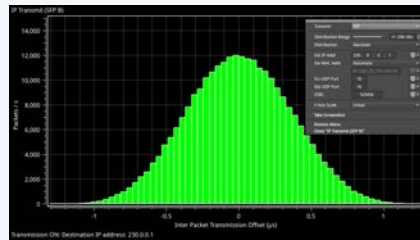

High Dynamic Range (HDR) visualization & analysis toolset [PHQXO-HDR]

The Qx's comprehensive HDR toolset includes a signal generator, CIE chart, Luma false color highlighting or *heat map*, waveform monitor and vectorscope. All the main live production SDR and HDR formats are supported: Standard Dynamic Range (SDR) BT.709, BT.2020 as well as HDR BT.2100 HLG, PQ and Sony S-Log3 and SR Live. The Waveform provides a Cd/m² (nits) graticule along with BT.2048 diffuse white markers. The flexible user controlled HDR heatmap offers seven simultaneous programmable color overlay bands with presets for HDR and SDR ranges, plus a user custom preset. The CIE 1931 xy display provides overlays for BT.709, BT.2020 and ST.2086 gamut (P3) to enhance the visualization and analysis of your HDR/WCG content.

HDR Generator

An extensive set of test patterns include BT.2111 HDR color bars for HLG, PQ and SR Live as well as a full set of SDR 709 patterns mapped via 'display light' to each of the four HDR formats for line checks, comparative monitor set-up and the evaluation of HDR to SDR converters.



False Color Highlighting

- Programmable Heat Map to highlight luminance zones providing quick identification of shadows, skin or mid-tones or specular highlights
- Seven simultaneous programmable color overlay bands
- Presets for HDR and SDR ranges plus user custom

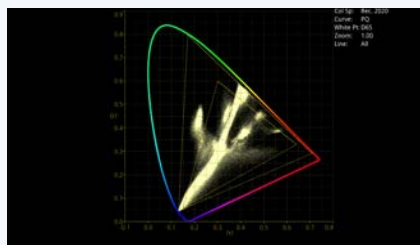

Analyzer - CIE Chart

- CIE 1931 xy display
- Single line mode linked to picture cursor
- Pan and zoom
- ITU-R BT. 709, BT. 2020 and ST 2086 gamut overlays
- Tooltip co-ordinate display
- Support for BT. 1886, BT. 2100 HLG and PQ, Sony S-Log3, SR Live

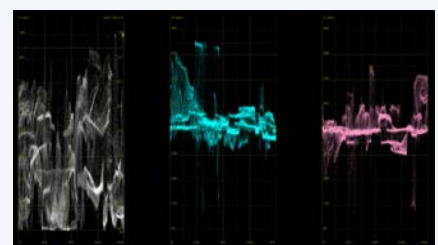

HDR Waveform

- Waveform HDR graticules with Nits (Cd/m²)
- BT. 2408 diffuse white markers
- Support for BT. 1886, BT. 2100 HLG and PQ, Sony S-Log3, SR Live



Specifications

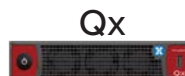

Formats supported (Generation, Analysis & Monitoring)	Qx	QxL	QxP
ST 2110-20/-30/-31/-40 / 2022-7 / 2022-6 Analysis over 10G Ethernet	○	●	●
ST 2110-20/-30/-31/-40 / 2022-7 / 2022-6 Analysis over 25G Ethernet	-	○	○
ST 2110-20/-30/-31/-40 / 2022-7 Generation	-	○	○
ST 2022-6 Generation	○	○	○
SDI IO	●	Factory Option	Factory Option
3G / 1.5G / 270M*-SDI HD / SD Analysis	●	Factory Option	Factory Option
3G / 1.5G / 270M*-SDI HD Generation	○	○ [†]	○ [†]
12G / 6G / 3G / 1.5G-SDI UHD Over SDI	○	○ [†]	○ [†]
25G IP Link Rates Over SFP28	-	○	○
Hardware and Software Options Supported			
Audio / Video Generator (SDI, ST 2022-6, ST 2110)	○ (SDI, 2022-6)	○ (SDI, 2022-6, 2110)	○ (SDI, 2022-6, 2110)
RTE™ Real-Time Eye input (12G/6G/3G/HD/SD-SDI) x 1 (SDI input A) BNC	Factory Option	Factory Option	Factory Option
UHD / 4K Upgrade	○ (SDI)	○ (SDI, 2110)	○ (SDI, 2110)
SDI-STRESS Testing Toolset (Requires SDI Eye and Jitter Toolset)	○	○	○
Data View Analyzer with ANC Inspector	●	●	●
HDR/WCG Support	○	○	○
Dolby E Analysis	○	○	○
ST 2022-6, ST 2110-20/30/31/40 Decap with ST 2022-7 and Dual PTP	○	●	●
ST 2110 Network Traffic Measurement Toolset	○	○	○
ST 2022-6 Network Traffic Generator Toolset	○	○	○
ST 2110 Generator Toolset	-	○	○
PCAP	○	○	○
EUHD Formats over 25G 2110-20	-	○	○
SDI inputs / outputs			
4 x SDI inputs, SD / HD / 3G, 75 ohm terminated BNC	●	Factory Option	Factory Option
2 x SFP+ MSA / Non-MSA cages (12 Gbps copper or fiber SDI interfaces)	●	Factory Option	Factory Option
4 x SDI outputs, SD* / HD / 3G, 75 ohm BNC	●	Factory Option	Factory Option
Ethernet inputs / outputs (accepts generic SFPs)			
2 x SFP+ 10G Cages (also MSA / Non-MSA 12Gbps copper or fiber SDI SFPs)	●	-	-
2 x SFP28 10 / 25G cages	-	●	●
2 x QSFP28 10 / 25 / 40 / 50 / 100G cages (For Future Functionality)	-	○	○
Audio inputs / outputs			
4 x 75 ohm AES selectable I/O (26 pin high-density D-Type socket)	●	●	●
1 x Stereo analog audio output (26 pin high-density D-Type socket)	●	●	●
8 channel 48 kHz PCM audio on HDMI and SDI Instrument output	●	●	●
User interface			
Integrated 1920 x 1200 7 inch LCD multitouch touchscreen	-	-	●
HDMI instrument output, 1920 x 1080, 4:4:4 RGB, Type A	HDMI 1.4	HDMI 2.0b	HDMI 2.0b
SDI 3Gbit instrument out, 1920 x 1080, 4:2:2 YCbCr	BNC	Micro BNC	Micro BNC
ST 2110-20, ST 2110-30 instrument out, 1920 x 1080, 4:2:2 YCbCr	-	●	●
Remote Browser GUI access (noVNC)	●	●	●
Reference			
2 x 75 ohm BNC looping reference input, tri-level or B&B with cross lock	●	-	-
1 x 75 ohm Micro-BNC reference input, Tri/B&B with cross lock	-	●	●
Networking & control			
10/100/1000 BASE-T	●	●	●
8 x bi-directional GPI (26 pin high-density D-Type socket)	●	●	●
Monitoring			
Internal Beeper	●	●	-
Integral Speaker / Headphone Socket	-	-	●
Form factor			
Size (Width x Height x Depth - excluding projections)	211 x 44 x 253 mm	211 x 44 x 253 mm	215 x 132 x 330 mm
Weight	1.9 kg	1.9 kg	4.1 kg [†]
Electrical			
Power consumption	50 W typical, 70 W max	100 W typical, 120 W max	110 W typical, 160 W max
4 Pin XLR power connector	12V nominal (10-18 V)	12 V nominal (10-18 V)	12 V nominal (11-18 V)
AC power adapter	90-264 VAC, 120 W	90-264 VAC, 120 W	90-264 VAC, 160 W
Integral PSU with IEC connector	-	-	●
Choice of External Battery V-mount or G-mount	-	-	●
Warranty			
Warranty (1 year)	●	●	●
Extended Warranty Package (3 - 5 years)	○	○	○

Qx Rear panel

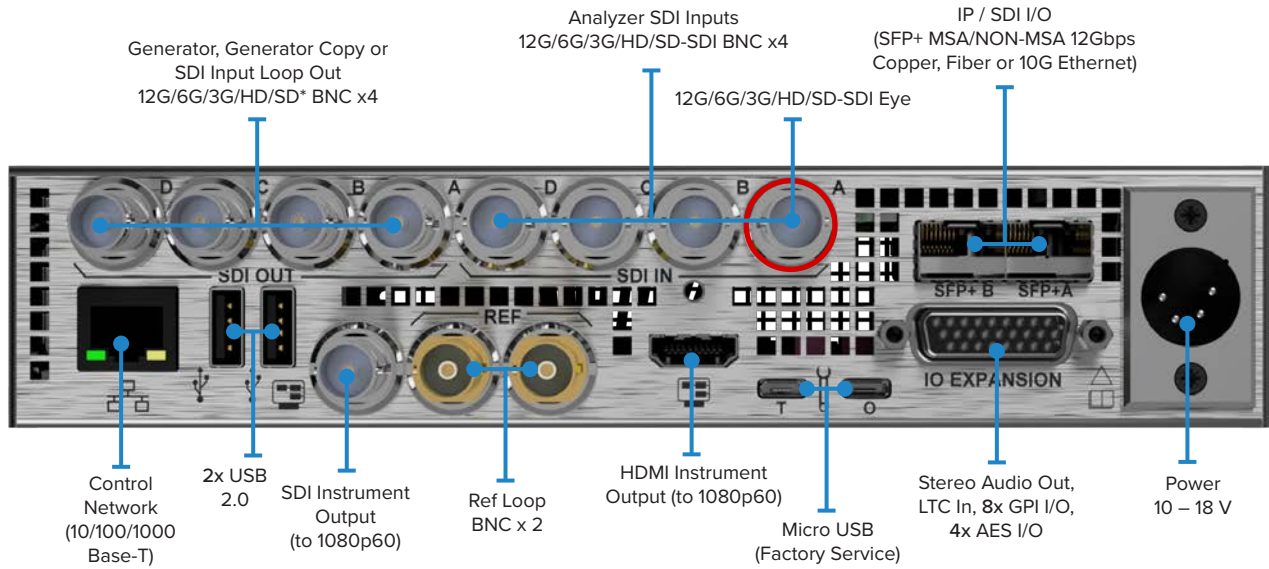

Qx Mezzanine Interface Card Block Diagram

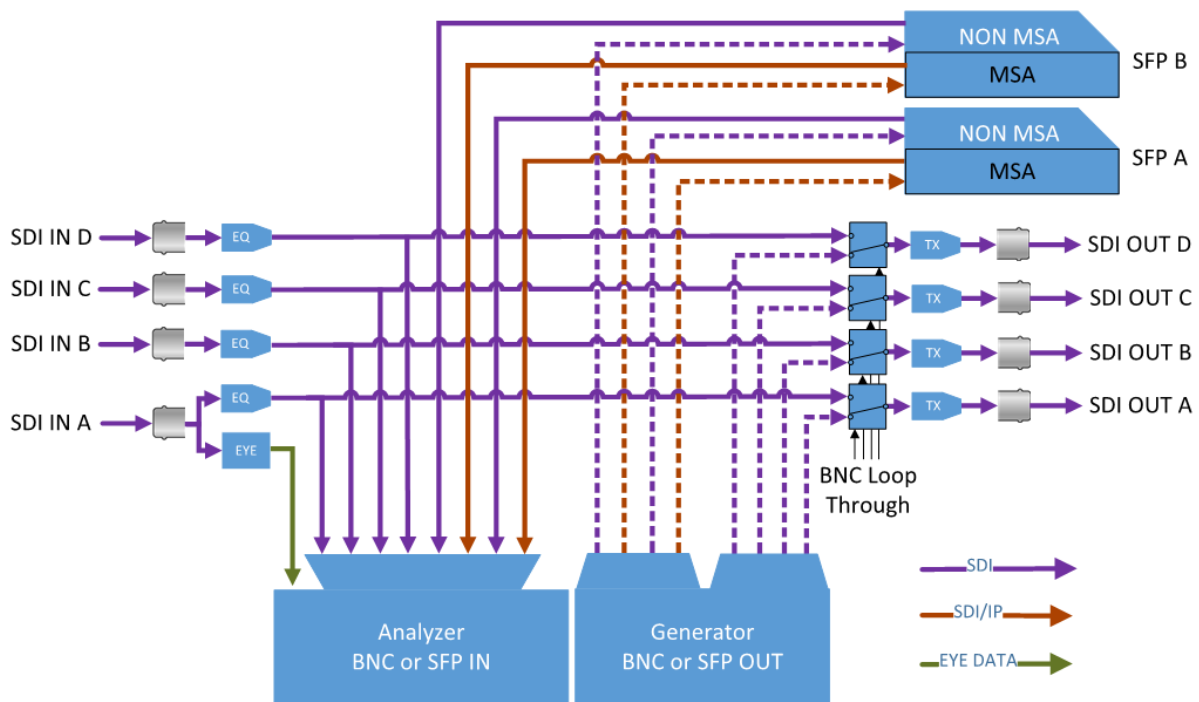

Ordering Qx

Qx Chassis

PHQX01-3G	Qx 1U SD/HD/2K SDI Rasterizer, Analyser only
PHQX01E-3G	Qx 1U SD/HD/2K SDI Rasterizer with Eye & Jitter, Analyser only
PHQXM-01E	Qx Eye/Jitter return to factory upgrade (for PHQX01-3G chassis)

Qx SDI Options

PHQXO-UHD	SDI 2K Extended + UHD/4K 4xHD/6G/4x3G/2x6G/12G-SDI
PHQXO-SDI-STRESS	12G-SDI Stress Test Toolset (requires PHQX01E-3G, PHQXO-UHD, PHQXO-GEN)
PHSFP-RT12-1310	SFP+ SM(10km) LC Non-MSA, Tx 1310nm, Rx 1260-1620nm 12G/6G/3G/HD/SD*-SDI

Qx SDI/IP Software Options

PHQXO-DOLBY	Dolby E Decoder, Metadata Analyser, LtRt/LoRo downmix, metering
PHQXO-GEN	SDI/2022-6 AV Test Signal Generator (2022-6 requires PHQXO-IP-STND)
PHQXO-HDR	HDR/WCG, CIE1931, HDR Heat map (PQ, HLG, S-Log3, SR Live)

Qx IP Options

PHQXO-IP-STND	2022-6 Encap/Decap, 2110 Decap with 2022-7, dual PTP, NMOS IS-04/05
PHQXO-IP-MEAS	IP Measurement 2110-21, PIT histograms, timing (requires PHQXO-IP-STND)
PHQXO-IP-PCAP	PCAP 2x10Gbps line rate capture tool, 1GB max. (requires PHQXO-IP-STND)
PHQXO-IP-NGT	2022-6 IP Network traffic Generator Tool (requires PHQXO-IP-STND, PHQXO-GEN)
PHSFP-10GE-SR	SFP+ 10GBASE-SR Ethernet MM 850nm 300m (requires PHQXO-IP-STND)
PHSFP-10GE-LR	SFP+ 10GBASE-LR Ethernet SM 1310nm 10km (requires PHQXO-IP-STND)

Qx Fitting Kits / Cables

PHQXC-1	12G-SDI Eye Measurement Test Cable 1m
PHQXK1	19 inch rackmount kit (1x Qx/QxL chassis)
PHQXK2	19 inch rackmount kit (2x Qx/QxL chassis)
PHQXK3	9.5 inch rackmount kit (1x Qx/QxL chassis)

Qx Extended Warranty

PHQX01-3YEAR	PHQX01 Upgrade from 1 to 3 Year Warranty (excludes SFP)
PHQX01-5YEAR	PHQX01 Upgrade from 1 to 5 Year Warranty (excludes SFP)
PHQX01E-3YEAR	PHQX01E Upgrade from 1 to 3 Year Warranty (excludes SFP)
PHQX01E-5YEAR	PHQX01E Upgrade from 1 to 5 Year Warranty (excludes SFP)

SDI SFP Interfaces

SDI SFP Interface	Link Type	SFP+B Link Rates		SFP+A Link Rates	
SDI Transceivers Only					
One SDI Transceiver in Cage A	SFP Interface	N/A	N/A	Rx Ch1	Tx Ch1
	Single Link: Rx/Tx	N/A	N/A	BNC A Rx 0.27/1.5/3/6/12	BNC A Tx 0.27/1.5/3/6/12
	Dual Link: N/A	N/A	N/A	N/A	N/A
	Quad Link: N/A	N/A	N/A	N/A	N/A
Two SDI Transceivers in Cages A & B	SFP Interface	Rx Ch1	Tx Ch1	Rx Ch1	Tx Ch1
	Single Link: Rx/Tx	N/A	BNC C Tx (Tx Copy) 0.27*/1.5/3/6/12	BNC A Rx 0.27/1.5/3/6/12	BNC A Tx 0.27*/1.5/3/6/12
	Dual Link: Rx/Tx	BNC C Rx 0.27*/1.5/3/6	BNC C Tx 0.27*/1.5/3/6	BNC A Rx 0.27/1.5/3/6	BNC A Tx 0.27*/1.5/3/6
	Quad Link: N/A	N/A	N/A	N/A	N/A
SDI Dual Receivers Only					
One SDI Dual Receiver in Cage A	SFP Interface	N/A	N/A	Rx Ch1	Rx Ch2
	Single Link: Rx	N/A	N/A	BNC A Rx 0.27/1.5/3/6/12	N/A
	Dual Link: Rx	N/A	N/A	BNC A Rx 0.27/1.5/3/6	BNC B Rx 0.27*/1.5/3/6
	Quad Link: N/A	N/A	N/A	N/A	N/A
Two SDI Dual Receivers in Cages A & B	SFP Interface	Rx Ch1	Rx Ch2	Rx Ch1	Rx Ch2
	Single Link: Rx	N/A	N/A	BNC A Rx 0.27/1.5/3/6/12	N/A
	Dual Link: Rx	N/A	N/A	BNC A Rx 0.27/1.5/3/6	BNC B Rx 0.27*/1.5/3/6
	Quad Link: Rx ^{1 2}	BNC C Rx 0.27*/1.5/3	BNC D Rx 0.27*/1.5/3	BNC A Rx 0.27/1.5/3	BNC B Rx 0.27*/1.5/3
SDI Dual Transmitters Only					
One SDI Dual Transmitter in Cage A	SFP Interface	N/A	N/A	Tx Ch2	Tx Ch1
	Single Link: Tx	N/A	N/A	BNC B Tx (Tx Copy) 0.27*/1.5/3/6	BNC A Tx 0.27*/1.5/3/6/12
	Dual Link: Tx	N/A	N/A	BNC B Tx 0.27*/1.5/3/6	BNC A Tx 0.27*/1.5/3/6
	Quad Link: N/A	N/A	N/A	N/A	N/A
Two SDI Dual Transmitters in Cages A & B	SFP Interface	Tx Ch2	Tx Ch1	Tx Ch2	Tx Ch1
	Single Link: Tx	BNC D Tx (Tx Copy) 0.27*/1.5/3/6	BNC C Tx (Tx Copy) 0.27*/1.5/3/6/12	BNC B Tx (Tx Copy) 0.27*/1.5/3/6	BNC A Tx 0.27*/1.5/3/6/12
	Dual Link: Tx	BNC D Tx (Tx Copy) 0.27*/1.5/3/6	BNC C Tx (Tx Copy) 0.27*/1.5/3/6	BNC B Tx 0.27*/1.5/3/6	BNC A Tx 0.27*/1.5/3/6
	Quad Link: Tx ^{2 3}	BNC D Tx 0.27*/1.5/3	BNC C Tx 0.27*/1.5/3	BNC B Tx 0.27*/1.5/3	BNC A Tx 0.27*/1.5/3
SDI Dual Transmitter plus SDI Dual Receiver					
One SDI Dual Transmitter (Cage A) and One Dual SDI Receiver (Cage B)	SFP Interface	Rx Ch1	Rx Ch2	Tx Ch2	Tx Ch1
	Single Link: Rx/Tx	BNC C Rx 0.27*/1.5/3/6/12 ⁴	N/A	BNC B Tx (Tx Copy) 0.27*/1.5/3/6	BNC A Tx 0.27*/1.5/3/6/12
	Dual Link: Rx/Tx	BNC C Rx 0.27*/1.5/3/6	BNC D Rx 0.27*/1.5/3/6	BNC B Tx 0.27*/1.5/3/6	BNC A Tx 0.27*/1.5/3/6
	Quad Link: N/A	N/A	N/A	N/A	N/A

¹ In quad link 2SI the Receivers will auto adapt to any order of sub-image to BNC mapping.

² In quad link square division the sub image order is: BNC A:TL, BNC B:TR, BNC C:BL, BNC D:BR.

³ In quad link 2SI the sub image order is: BNC A:Sub 1, BNC B:Sub 2, BNC C:Sub 3, BNC D:Sub 4.

⁴ SD-SDI (270M (0.27G)) video is not supported for Mixed Dual Transmitters and Receivers

Supported 2K/HD/SD SDI Formats

The following SDI formats are standard on the Qx.

SMPTE Stnds. Link (Content)	Interface	Resolution	Sampling Structure	Pixel Depth	Frame/Field Rate	HDR †	SDI	2022-6‡
ST 259 (ST 125)	SD (625i)	720 x 576	4:2:2 (YCbCr)	10	50i	-	A	OA
ST 259 (ST 125)	SD (525i)	720 x 485	4:2:2 (YCbCr)	10	59.94i	-	A	OA
ST 292 (ST 296)	HD	1280 x 720	4:2:2 (YCbCr)	10	60p, 59.94p, 50p, 30p, 29.97p, 25p,	○●	●	○●
ST 292 (ST 274)	HD	720 x 485	4:2:2 (YCbCr)	10	60i, 59.94i, 50i 30p, 29.97p, 25p, 24p, 23.98p	○●	●	○●
ST 292 (RP 211)	HD	1920 x 1080	4:2:2 (YCbCr)	10	30psF, 29.97PsF, 25psF, 24PsF, 23.98PsF	○●	●	○●
ST 292 (ST 2048-2)	HD	2048 x 1080	4:2:2 (YCbCr)	10	30p, 29.97p, 25p, 24p, 23.98p, 30PsF, 29.97PsF, 25PsF, 24PsF, 23.98PsF	○●	●	○●
ST 372 (ST 274)	Dual Link HD	1920 x 1080	4:2:2 (YCbCr)	10	60p, 59.94p, 50p	○●	●	-
ST 372 (ST 274)	Dual Link HD	1920 x 1080	4:4:4 (YCbCr/RGB) 4:4:4:4 (YCbCrA/RGBA)	10	60i, 59.94i, 50i, 30PsF, 29.97PsF, 25PsF, 24PsF, 23.98PsF 30p, 29.97p, 25p, 24p, 23.98p	○●	●	-
ST 372 (ST 274)	Dual Link HD	1920 x 1080	4:4:4 (YCbCr/RGB)	12	60i, 59.94i, 50i 30p, 29.97p, 25p, 24p, 23.98p	○●	●	-
ST 372 (ST 274)	Dual Link HD	1920 x 1080	4:2:2 (YCbCr)	12	60i, 59.94i, 50i, 30PsF, 29.97PsF, 25PsF, 24PsF, 23.98PsF 30p, 29.97p, 25p, 24p, 23.98p	○●	●	-
ST 372 (ST 2048-2)	Dual Link HD	2048 x 1080	4:2:2 (YCbCr)	10	60p, 59.94p, 50p, 48p, 47.95p	○●	●	-
ST 372 (ST 2048-2)	Dual Link HD	2048 x 1080	4:4:4 (YCbCr/RGB) 4:4:4:4 (YCbCrA/RGBA)	10	30PsF, 29.97PsF, 25PsF, 24PsF, 23.98PsF 30p, 29.97p, 25p, 24p, 23.98p	○●	●	-
ST 372 (ST 2048-2)	Dual Link HD	2048 x 1080	4:4:4 (YCbCr/RGB)	12	30PsF, 29.97PsF, 25PsF, 24PsF, 23.98PsF 30p, 29.97p, 25p, 24p, 23.98p	○●	●	-
ST 372 (ST 2048-2)	Dual Link HD	2048 x 1080	4:2:2 (YCbCr) 4:2:2:4 (YCbCrA)	12	30PsF, 29.97PsF, 25PsF, 24PsF, 23.98PsF 30p, 29.97p, 25p, 24p, 23.98p	○●	●	-
ST 425-1 (ST 274)	3G Level A (I)	1920 x 1080	4:2:2 (YCbCr)	10	60p, 59.94p, 50p	○●	●	○●
ST 425-1 (ST 2048-2)	3G Level A (I)	2048 x 1080	4:2:2 (YCbCr)	10	60p, 59.94p, 50p, 48p, 47.95p	○●	●	○●
ST 425-1 (ST 296)	3G Level A (2)	1280 x 720	4:4:4 (YCbCr/RGB) 4:4:4:4 (YCbCrA/RGBA)	10	60p, 59.94p, 50p, 30p, 29.97p	○●	●	○●
ST 425-1 (ST 274)	3G Level A (2)	1920 x 1080	4:4:4 (YCbCr/RGB) 4:4:4:4 (YCbCrA/RGBA)	10	60i, 59.94i, 50i, 30PsF, 29.97PsF, 25PsF, 24PsF, 23.98PsF 30p, 29.97p, 25p, 24p, 23.98p	○●	●	○●
ST 425-1 (ST 2048-2)	3G Level A (2)	2048 x 1080	4:4:4 (YCbCr/RGB) 4:4:4:4 (YCbCrA/RGBA)	10	30PsF, 29.97PsF, 25PsF, 24PsF, 23.98PsF 30p, 29.97p, 25p, 24p, 23.98p	○●	●	○●
ST 425-1 (ST 274)	3G Level A (3)	1920 x 1080	4:4:4 (YCbCr/RGB)	12	60i, 59.94i, 50i, 30p, 29.97p, 25p, 24p, 23.98p	○●	●	○●
ST 425-1 (ST 2048-2)	3G Level A (3)	2048 x 1080	4:4:4 (YCbCr/RGB)	12	30PsF, 29.97PsF, 25PsF, 24PsF, 23.98PsF 30p, 29.97p, 25p, 24p, 23.98p	○●	●	○●
ST 425-1 (ST 274)	3G Level A (4)	1920 x 1080	4:2:2 (YCbCr) 4:2:2:4 (YCbCrA)	12	60i, 59.94i, 50i, 30PsF, 29.97PsF, 25PsF, 24PsF, 23.98PsF 30p, 29.97p, 25p, 24p, 23.98p	○●	●	○●
ST 425-1 (ST 2048-2)	3G Level A (4)	2048 x 1080	4:2:2 (YCbCr) 4:2:2:4 (YCbCrA)	12	30PsF, 29.97PsF, 25PsF, 24PsF, 23.98PsF 30p, 29.97p, 25p, 24p, 23.98p	○●	●	○●
ST 425-1 (ST 274)	3G Level B-DL (I)	1920 x 1080	4:2:2 (YCbCr)	10	60p, 59.94p, 50p	○●	●	○●
ST 425-1 (ST 2048-2)	3G Level B-DL (I)	2048 x 1080	4:2:2 (YCbCr)	10	60p, 59.94p, 50p, 48p, 47.95p	○●	●	○●
ST 425-1 (ST 274)	3G Level B-DL (II)	1920 x 1080	4:4:4 (YCbCr/RGB) 4:4:4:4 (YCbCrA/RGBA)	10	60i, 59.94i, 50i, 30PsF, 29.97PsF, 25PsF, 24PsF, 23.98PsF 30p, 29.97p, 25p, 24p, 23.98p	○●	●	○●
ST 425-1 (ST 2048-2)	3G Level B-DL (II)	2048 x 1080	4:4:4 (YCbCr/RGB) 4:4:4:4 (YCbCrA/RGBA)	10	30PsF, 29.97PsF, 25PsF, 24PsF, 23.98PsF 30p, 29.97p, 25p, 24p, 23.98p	○●	●	○●
ST 425-1 (ST 274)	3G Level B-DL (III)	1920 x 1080	4:4:4 (YCbCr/RBG)	12	60i, 59.94i, 50i, 30p, 29.97p, 25p, 24p, 23.98p	○●	●	○●
ST 425-1 (ST 2048-2)	3G Level B-DL (III)	2048 x 1080	4:4:4 (YCbCr/RBG)	12	30PsF, 29.97PsF, 25PsF, 24PsF, 23.98PsF 30p, 29.97p, 25p, 24p, 23.98p	○●	●	○●
ST 425-1 (ST 274)	3G Level B-DL (IV)	1920 x 1080	4:2:2 (YCbCr)	12	60i, 59.94i, 50i, 30PsF, 29.97PsF, 25PsF, 24PsF, 23.98PsF 30p, 29.97p, 25p, 24p, 23.98p	○●	●	○●
ST 425-1 (ST 2048-2)	3G Level B-DL (IV)	2048 x 1080	4:2:2 (YCbCr) 4:2:2:4 (YCbCrA)	12	30PsF, 29.97PsF, 25PsF, 24PsF, 23.98PsF 30p, 29.97p, 25p, 24p, 23.98p	○●	●	○●

† Note: Optional HDR formats require PHQXO-HDR

‡ Note: ST 2022-6 formats require PHQXO-IP-STND

KEY

- - Generator with PHQXO-GEN option and Analyzer
- - Optional
- - Optional Generator with PHQXO-GEN option and Analyzer
- A - Analyzer Only
- '-' - Not Available

Supported 2K/HD/SD IP Formats

The following 2K/HD ST 2110-20 formats are optional on the Qx with PHQXO-IP-STND

Resolution	Sampling Structure	Pixel Depth	Frame/Field Rate	2110 HDR †	2110 SDR
720 x 576	4:2:2 (YCbCr)	10	50i	-	OA
720 x 485	4:2:2 (YCbCr)	10	59.94i	-	OA
1280 x 720	4:2:2 (YCbCr)	8	60p, 59.94p, 50p, 48p, 47.97p, 30p, 29.97p, 25p, 24p, 23.98p	OA	OA
1280 x 720	4:2:2 (YCbCr)	10	60p, 59.94p, 50p, 48p, 47.97p, 30p, 29.97p, 25p, 24p, 23.98p	OA	OA
1280 x 720	4:4:4(YCbCr/RGB)	8	60p, 59.94p, 50p, 48p, 47.97p, 30p, 29.97p, 25p, 24p, 23.98p	OA	OA
1280 x 720	4:4:4(YCbCr/RGB)	10	60p, 59.94p, 50p, 48p, 47.97p, 30p, 29.97p, 25p, 24p, 23.98p	OA	OA
1920 x 1080	4:2:2(YCbCr)	8	60i, 59.94i, 50i	OA	OA
1920 x 1080	4:2:2 (YCbCr)	10	60i, 59.94i, 50i	OA	OA
1920 x 1080	4:2:2(YCbCr)	12	60i, 59.94i, 50i	OA	OA
1920 x 1080	4:4:4(YCbCr/RGB)	8	60i, 59.94i, 50i	OA	OA
1920 x 1080	4:4:4(YCbCr/RGB)	10	60i, 59.94i, 50i	OA	OA
1920 x 1080	4:4:4(YCbCr/RGB)	12	60i, 59.94i, 50i	OA	OA
1920 x 1080	4:2:2 (YCbCr)	8	60p, 59.94p, 50p, 48p, 47.97p, 30p, 29.97p, 25p, 24p, 23.98p	OA	OA
1920 x 1080	4:2:2 (YCbCr)	10	60p, 59.94p, 50p, 48p, 47.97p, 30p, 29.97p, 25p, 24p, 23.98p	OA	OA
1920 x 1080	4:2:2 (YCbCr)	12	60p, 59.94p, 50p, 48p, 47.97p, 30p, 29.97p, 25p, 24p, 23.98p	OA	OA
1920 x 1080	4:4:4(YCbCr/RGB)	8	60p, 59.94p, 50p, 48p, 47.97p, 30p, 29.97p, 25p, 24p, 23.98p	OA	OA
1920 x 1080	4:4:4(YCbCr/RGB)	10	60p, 59.94p, 50p, 48p, 47.97p, 30p, 29.97p, 25p, 24p, 23.98p	OA	OA
1920 x 1080	4:4:4(YCbCr/RGB)	12	60p, 59.94p, 50p, 48p, 47.97p, 30p, 29.97p, 25p, 24p, 23.98p	OA	OA
1920 x 1080	4:2:2 (YCbCr)	8	30PsF, 29.97PsF, 25PsF, 24PsF, 23.97PsF	OA	OA
1920 x 1080	4:2:2 (YCbCr)	10	30PsF, 29.97PsF, 25PsF, 24PsF, 23.98PsF	OA	OA
1920 x 1080	4:2:2 (YCbCr)	12	30PsF, 29.97PsF, 25PsF, 24PsF, 23.97PsF	OA	OA
1920 x 1080	4:4:4(YCbCr/RGB)	8	30PsF, 29.97PsF, 25PsF, 24psF, 23.97PsF	OA	OA
1920 x 1080	4:4:4(YCbCr/RGB)	10	30psF, 29.97psF, 25psF, 24PsF, 23.97PsF	OA	OA
1920 x 1080	4:4:4(YCbCr/RGB)	12	30PsF, 29.97PsF, 25PsF, 24PsF, 23.97PsF	OA	OA
2048 x 1080	4:2:2 (YCbCr)	8	60p, 59.94p, 50p, 48p, 47.97p, 30p, 29.97p, 25p, 24p, 23.98p	OA	OA
2048 x 1080	4:2:2 (YCbCr)	10	60p, 59.94p, 50p, 48p, 47.97p, 30p, 29.97p, 25p, 24p, 23.98p	OA	OA
2048 x 1080	4:2:2 (YCbCr)	12	60p, 59.94p, 50p, 48p, 47.97p, 30p, 29.97p, 25p, 24p, 23.98p	OA	OA
2048 x 1080	4:4:4(YCbCr/RGB)	8	60p, 59.94p, 50p, 48p, 47.97p, 30p, 29.97p, 25p, 24p, 23.98p	OA	OA
2048 x 1080	4:4:4(YCbCr/RGB)	10	60p, 59.94p, 50p, 48p, 47.97p, 30p, 29.97p, 25p, 24p, 23.98p	OA	OA
2048 x 1080	4:4:4(YCbCr/RGB)	12	60p, 59.94p, 50p, 48p, 47.97p, 30p, 29.97p, 25p, 24p, 23.98p	OA	OA
2048 x 1080	4:2:2(YCbCr)	8	30PsF, 29.97PsF, 25PsF, 24PsF, 23.97PsF	OA	OA
2048 x 1080	4:2:2(YCbCr)	10	30PsF, 29.97PsF, 25PsF, 24PsF, 23.97PsF	OA	OA
2048 x 1080	4:2:2(YCbCr)	12	30PsF, 29.97PsF, 25PsF, 24PsF, 23.97PsF	OA	OA
2048 x 1080	4:4:4(YCbCr/RGB)	8	30PsF, 29.97PsF, 25PsF, 24PsF, 23.97PsF	OA	OA
2048 x 1080	4:4:4(YCbCr/RGB)	10	30PsF, 29.97PsF, 25PsF, 24PsF, 23.97PsF	OA	OA
2048 x 1080	4:4:4(YCbCr/RGB)	12	30PsF, 29.97PsF, 25PsF, 24PsF, 23.97PsF	OA	OA

† **Note:** Optional HDR formats require PHQXO-HDR

KEY
O - Optional
A - Analyzer Only
- - Not Available

* Upcoming Software Release

Supported 4K/UHD Formats

The following SDI formats are optional on the Qx [PHQXO-UHD]

SMPTE Stnds. Link (Content)	Interface	Resolution	Sampling Structure	Pixel Depth	Frame/Field Rate	SDI HDR †	SDI SDR
ST 425-3 Annex B.1 (ST 2036-1)	Quad-link HD-SQ	3840 x 2160	4:2:2 (YCbCr)	10	30p, 29.97p, 25p, 24p, 23.98p	○●	○●
ST 425-3 Annex B.1 (ST 2048-1)	Quad-link HD-SQ	4096 x 2160	4:2:2 (YCbCr)	10	30p, 29.97p, 25p, 24p, 23.98p	○●	○●
ST 425-3 Annex B.2, (ST 2036-1)	Dual 3G-B-DS	3840 x 2160	4:2:2 (YCbCr)	10	30p, 29.97p, 25p, 24p, 23.98p	○●	○●
ST 425-3 Annex B.2, (ST 2048-1)	Dual 3G-B-DS	4096 x 2160	4:2:2 (YCbCr)	10	30p, 29.97p, 25p, 24p, 23.98p	○●	○●
ST 2081-10 M1 (ST 2036-1)	6G-2SI	3840 x 2160	4:2:2 (YCbCr)	10	30p, 29.97p, 25p, 24p, 23.98p	○●	○●
ST 2081-10 M1 (ST 2048-1)	6G-2SI	4096 x 2160	4:2:2 (YCbCr)	10	30p, 29.97p, 25p, 24p, 23.98p	○●	○●
ST 425-5 (ST 2036-1)	Quad-link 3G-A, B (1) 2SI	3840 x 2160	4:2:2 (YCbCr)	10	60p, 59.94p, 50p	○●	○●
ST 425-5 (ST 2048-1)	Quad-link 3G-A, B (1) 2SI	4096 x 2160	4:2:2 (YCbCr)	10	60p, 59.94p, 50p, 48p, 47.95p	○●	○●
ST 425-5 (ST 2036-1)	Quad-link 3G-A, B (2) 2SI	3840 x 2160	4:4:4 (YCbCr/RGB)	10	30p, 29.97p, 25p, 24p, 23.98p	○●	○●
ST 425-5 (ST 2048-1)	Quad-link 3G-A, B (2) 2SI	4096 x 2160	4:4:4 (YCbCr/RGB) 4:4:4:4 (YCbCrA/RGBA)	10	30p, 29.97p, 25p, 24p, 23.98p	○●	○●
ST 425-5 (ST 2036-1)	Quad-link 3G-A, B (3) 2SI	3840 x 2160	4:4:4 (YCbCr/RGB)	12	30p, 29.97p, 25p, 24p, 23.98p	○●	○●
ST 425-5 (ST 2048-1)	Quad-link 3G-A, B (3) 2SI	4096 x 2160	4:4:4 (YCbCr/RGB)	12	30p, 29.97p, 25p, 24p, 23.98p	○●	○●
ST 425-5 (ST 2036-1)	Quad-link 3G-A, B (4) 2SI	3840 x 2160	4:2:2 (YCbCr)	12	30p, 29.97p, 25p, 24p, 23.98p	○●	○●
ST 425-5 (ST 2048-1)	Quad-link 3G-A, B (4) 2SI	4096 x 2160	4:2:2 (YCbCr) 4:2:2:4 (YCbCrA)	12	30p, 29.97p, 25p, 24p, 23.98p	○●	○●
ST 425-5 Annex B (ST 2036-1)	Quad-link 3G-A, B (1) SQ	3840 x 2160	4:2:2 (YCbCr)	10	60p, 59.94p, 50p	○●	○●
ST 425-5 Annex B (ST 2048-1)	Quad-link 3G-A, B (1) SQ	4096 x 2160	4:2:2 (YCbCr)	10	60p, 59.94p, 50p, 48p, 47.95p	○●	○●
ST 425-5 Annex B (ST 2036-1)	Quad-link 3G-A, B (2) SQ	3840 x 2160	4:4:4 (YCbCr/RGB)	10	30p, 29.97p, 25p, 24p, 23.98p	○●	○●
ST 425-5 Annex B, (ST 2048-1)	Quad-link 3G-A, B (2) SQ	4096 x 2160	4:4:4 (YCbCr/RGB) 4:4:4:4 (YCbCrA/RGBA)	10	30p, 29.97p, 25p, 24p, 23.98p	○●	○●
ST 425-5 Annex B (ST 2036-1)	Quad-link 3G-A, B (3) SQ	3840 x 2160	4:4:4 (YCbCr/RGB)	12	30p, 29.97p, 25p, 24p, 23.98p	○●	○●
ST 425-5 Annex B, (ST 2048-1)	Quad-link 3G-A, B (3) SQ	4096 x 2160	4:4:4 (YCbCr/RGB)	12	30p, 29.97p, 25p, 24p, 23.98p	○●	○●
ST 425-5 Annex B (ST 2036-1)	Quad-link 3G-A, B (4) SQ	3840 x 2160	4:2:2 (YCbCr)	12	30p, 29.97p, 25p, 24p, 23.98p	○●	○●
ST 425-5 Annex B (ST 2048-1)	Quad-link 3G-A, B (4) SQ	4096 x 2160	4:2:2 (YCbCr) 4:2:2:4 (YCbCrA)	12	30p, 29.97p, 25p, 24p, 23.98p	○●	○●
ST 2081-11 M1, ST 425-5 (ST 2036-1)	Dual-link 6G-2SI (I)	3840 x 2160	4:2:2 (YCbCr)	10	60p, 59.94p, 50p	○●	○●
ST 2081-11 M1, ST 425-5 (ST 2048-1)	Dual-link 6G-2SI (I)	4096 x 2160	4:2:2 (YCbCr)	10	60p, 59.94p, 50p, 48p, 47.95p	○●	○●
ST 2081-11 M1, ST 425-5 (ST 2036-1)	Dual-link 6G-2SI (II)	3840 x 2160	4:4:4 (YCbCr/RGB)	10	30p, 29.97p, 25p, 24p, 23.98p	○●	○●
ST 2081-11 M1, ST 425-5 (ST 2048-1)	Dual-link 6G-2SI (II)	4096 x 2160	4:4:4 (YCbCr/RGB) 4:4:4:4 (YCbCrA/RGBA)	10	30p, 29.97p, 25p, 24p, 23.98p	○●	○●
ST 2081-11 M1 ST 425-5 (ST 2036-1)	Dual-link 6G-2SI (III)	3840 x 2160	4:4:4 (YCbCr/RGB)	12	30p, 29.97p, 25p, 24p, 23.98p	○●	○●
ST 2081-11 M1, ST 425-5 (ST 2048-1)	Dual-link 6G-2SI (III)	4096 x 2160	4:4:4 (YCbCr/RGB)	12	30p, 29.97p, 25p, 24p, 23.98p	○●	○●
ST 2081-11 M1 ST 425-5 (ST 2036-1)	Dual-link 6G-2SI (IV)	3840 x 2160	4:2:2 (YCbCr/RGB)	12	30p, 29.97p, 25p, 24p, 23.98p	○●	○●
ST 2081-11 M1 ST 425-5 (ST 2048-1)	Dual-link 6G-2SI (IV)	4096 x 2160	4:2:2 (YCbCr) 4:2:2:4 (YCbCrA)	12	30p, 29.97p, 25p, 24p, 23.98p	○●	○●
ST 2082-10 M1, ST 425-5 (ST 2036-1)	12G-2SI (I)	3840 x 2160	4:2:2 (YCbCr)	10	60p, 59.94p, 50p	○●	○●
ST 2082-10 M1, ST 425-5 (ST 2048-1)	12G-2SI (I)	4096 x 2160	4:2:2 (YCbCr)	10	60p, 59.94p, 50p, 48p, 47.95p	○●	○●
ST 2082-10 M1 ST 425-5 (ST 2036-1)	12G -2SI (II)	3840 x 2160	4:4:4 (YCbCr/RGB) 4:4:4:4 (YCbCrA/RGBA)	10	30p, 29.97p, 25p, 24p, 23.98p	○●	○●
ST 2082-10 M1 ST 425-5 (ST 2048-1)	12G -2SI (II)	4096 x 2160	4:4:4 (YCbCr/RGB) 4:4:4:4 (YCbCrA/RGBA)	10	30p, 29.97p, 25p, 24p, 23.98p	○●	○●
ST 2082-10 M1 ST 425-5 (ST 2036-1)	12G-2SI (III)	3840 x 2160	4:4:4 (YCbCr/RGB)	12	30p, 29.97p, 25p, 24p, 23.98p	○●	○●
ST 2082-10 M1 ST 425-5 (ST 2048-1)	12G-2SI (III)	4096 x 2160	4:4:4 (YCbCr/RGB)	12	30p, 29.97p, 25p, 24p, 23.98p	○●	○●
ST 2082-10 M1 ST 425-5 (ST 2036-1)	12G-2SI (IV)	3840 x 2160	4:2:2 (YCbCr) 4:2:2:4 (YCbCrA)	12	30p, 29.97p, 25p, 24p, 23.98p	○●	○●
ST 2082-10 M1 ST 425-5 (ST 2048-1)	12G-2SI (IV)	4096 x 2160	4:2:2 (YCbCr) 4:2:2:4 (YCbCrA)	12	30p, 29.97p, 25p, 24p, 23.98p	○●	○●

† Note: Optional HDR formats require PHQXO-HDR

KEY

○ - Optional

○● - Optional Generator with PHQXO-GEN option and Analyzer

⌚ - Not Available

Supported 4K/UHD IP Formats [QxL/QxP Only]

The following 4K/UHD ST 2110-20 formats are optional and can be added to QxL/QxP only [PHQXLO-UHD / PHQXPO-UHD].

Resolution	Sampling Structure	Pixel Depth	Frame/Field Rate	QxL/QxP	
				2110 HDR †	2110 SDR
3840 x 2160	4:2:2 (YCbCr)	8	60p, 59.94p, 50p, 48p, 47.97p, 30p, 29.97p, 25p, 24p, 23.98p	OA	A
3840 x 2160	4:2:2 (YCbCr)	10	60p, 59.94p, 50p, 48p, 47.97p, 30p, 29.97p, 25p, 24p, 23.98p	O●	●
3840 x 2160	4:2:2 (YCbCr)	12	60p, 59.94p, 50p, 48p, 47.97p, 30p, 29.97p, 25p, 24p, 23.98p	O●	●
3840 x 2160	4:4:4(YCbCr/RGB)	8	30p, 29.97p, 25p, 24p, 23.98p	OA	A
3840 x 2160	4:4:4(YCbCr/RGB)	10	30p, 29.97p, 25p, 24p, 23.98p	O●	●
3840 x 2160	4:4:4(YCbCr/RGB)	12	30p, 29.97p, 25p, 24p, 23.98p	O●	●
4096 x 2160	4:2:2(YCbCr)	8	60p, 59.94p, 50p, 48p, 47.97p, 30p, 29.97p, 25p, 24p, 23.98p	OA	A
4096 x 2160	4:2:2 (YCbCr)	10	60p, 59.94p, 50p, 48p, 47.95p, 30p, 29.97p, 25p, 24p, 23.98p	O●	●
4096 x 2160	4:2:2 (YCbCr)	12	60p, 59.94p, 50p, 48p, 47.95p, 30p, 29.97p, 25p, 24p, 23.98p	O●	●
4096 x 2160	4:4:4(YCbCr/RGB)	8	30p, 29.97p, 25p, 24p, 23.98p	OA	A
4096 x 2160	4:4:4(YCbCr/RGB)	10	30p, 29.97p, 25p, 24p, 23.98p	O●	●
4096 x 2160	4:4:4(YCbCr/RGB)	12	30p, 29.97p, 25p, 24p, 23.98p	O●	●

The following 4K/UHD ST 2110-20 extended formats are optional and can be added to QxL/QxP only [PHQXLO-EUHD / PHQXPO-EUHD].

Resolution	Sampling Structure	Pixel Depth	Frame/Field Rate	QxL/QxP	
				2110 HDR †	2110 SDR
3840 x 2160	RGB:444	8	60p, 59.94p, 50p, 48p, 47.97p	OA	OA
3840 x 2160	RGB:444	10	60p, 59.94p, 50p, 48p, 47.97p	OA	OA
3840 x 2160	RGB:444	12	660p, 59.94p, 50p, 48p, 47.97p	OA	OA
3840 x 2160	YCbCr:444	8	60p, 59.94p, 50p, 48p, 47.97p	OA	OA
3840 x 2160	YCbCr:444	10	60p, 59.94p, 50p, 48p, 47.97p	OA	OA
3840 x 2160	YCbCr:444	12	60p, 59.94p, 50p, 48p, 47.97p	OA	OA
4K Formats					
4096 x 2160	RGB:444	8	60p, 59.94p, 50p, 48p, 47.97p	OA	OA
4096 x 2160	RGB:444	10	60p, 59.94p, 50p, 48p, 47.97p	OA	OA
4096 x 2160	RGB:444	12	60p, 59.94p, 50p, 48p, 47.97p	OA	OA
4096 x 2160	YCbCr:444	8	60p, 59.94p, 50p, 48p, 47.97p	OA	OA
4096 x 2160	YCbCr:444	10	60p, 59.94p, 50p, 48p, 47.97p	OA	OA
4096 x 2160	YCbCr:444	12	60p, 59.94p, 50p, 48p, 47.97p	OA	OA

† **Note:** Optional HDR formats require PHQXLO-HDR / PHQXPO-HDR

KEY

- - Generator with PHQXLO-GEN / PHQXPO-GEN option and Analyzer
- O - Optional
- O● - Optional Generator with PHQXLO-GEN / PHQXPO-GEN option and Analyzer
- A - Analyzer Only
- '-' - Not Available

Dimensions and Installation

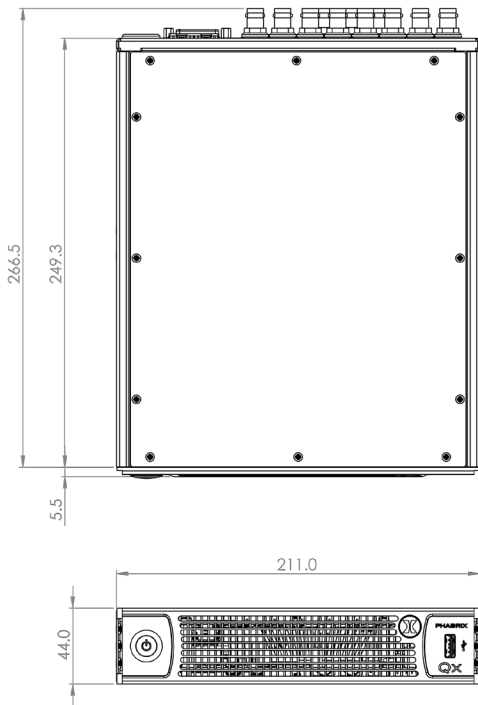

Desktop

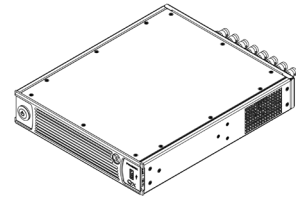

Single Rack mount tray with cover
PHQXK1

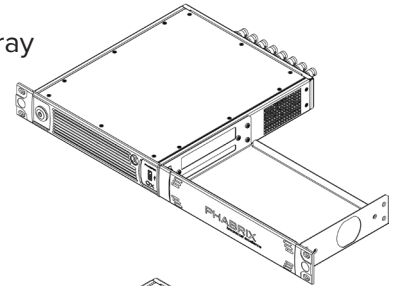

Dual Rack mount
PHQXK2

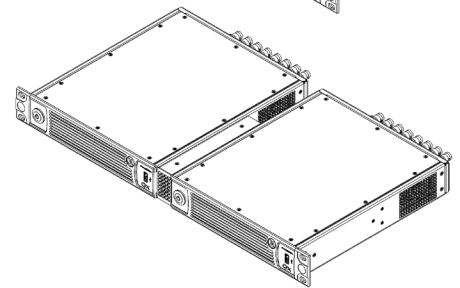

PHABRIX®
A Leader Company

Leader

www.phabrix.com



This brochure is to be used for informational use only and is subject to change without notice and should not be construed as commitment by Leader Electronics of Europe Limited. Leader Electronics of Europe Limited assumes no responsibility or liability for errors or inaccuracies that may appear in this brochure.

Please visit www.phabrix.com for latest product information
July 2024